



STATE OF NORTH CAROLINA
DEPARTMENT OF TRANSPORTATION

ROY COOPER
GOVERNOR

J.R. "JOEY" HOPKINS
SECRETARY

December 12, 2023

CONTRACT: DB00486
TIP NUMBER: W-5702G and W-5702R
WBS ELEMENT: 44848.3.7 and 44848.3.18
COUNTY: BEAUFORT
ROUTE: US 264
DESCRIPTION: CONVERT INTERSECTIONS TO UNSIGNALIZED RCI'S ON
US 264 IN BEAUFORT COUNTY

ADDENDUM 1

TO: PROSPECTIVE BIDDERS

Please note the following revisions to the proposal.

- Revised Plan pages TMP-01 to TMP-17 dated December 11, 2023.

Please make sure to sign the addendum page in the proposal to acknowledge this addendum.

Sincerely,

DocuSigned by:
Mary Voelker Moore
714C11DCCCEBC4C6...

Mary Voelker Moore, PE
Division Contract Engineer

cc: Ms. Heather C. Lane, PE
Ms. Sarah Lentine, PE
Mr. Cadmus Capehart, PE
Mr. Jordan Scott, PE
Mr. Lang Jones
Mr. Chris Smith
Mr. Jim Evans

Mailing Address:
NC DEPARTMENT OF TRANSPORTATION
DIVISION 2
PROJECT DEVELOPMENT GROUP
GREENVILLE, NC 27834

Telephone: (252) 439-2828
Customer Service: 1-877-368-4968

Website: www.ncdot.gov

Location:
1037 W.H. SMITH BLVD.
GREENVILLE, NC 27834

STATE OF NORTH CAROLINA
DIVISION OF HIGHWAYS

TRANSPORTATION MANAGEMENT PLAN

BEAUFORT COUNTY

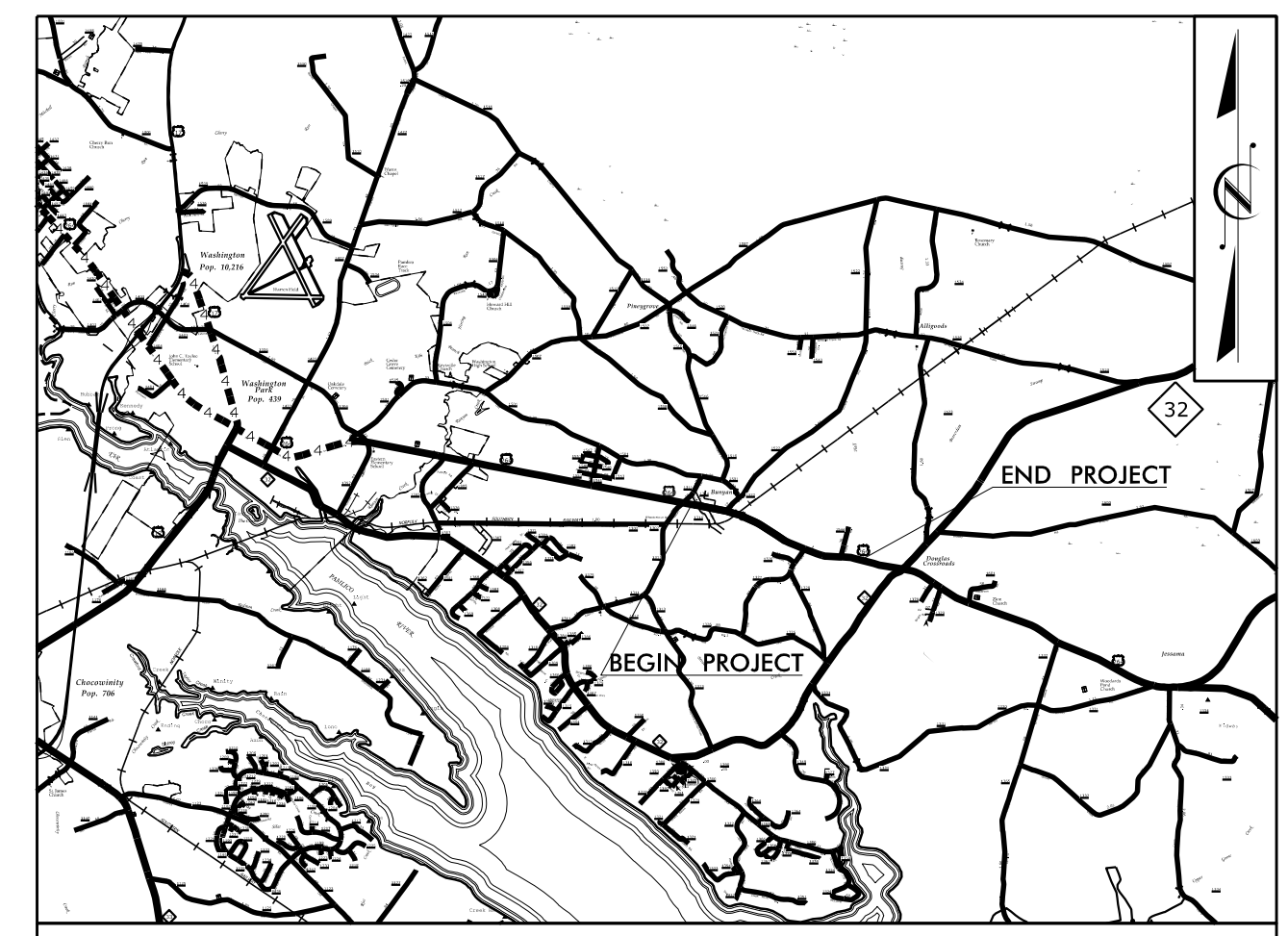
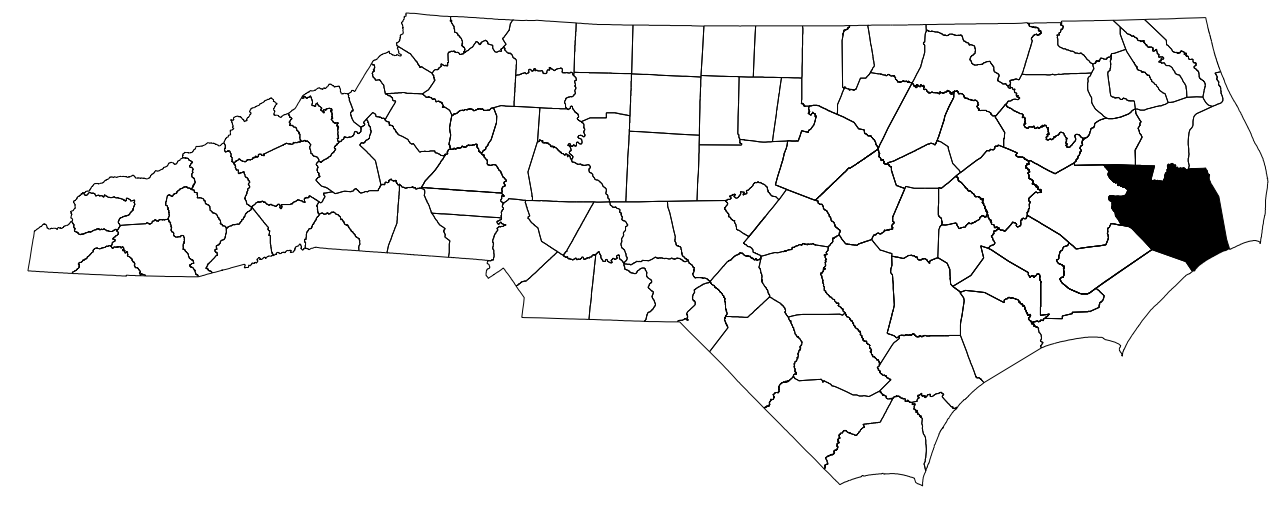

VICINITY MAP = NOT TO SCALE

**LOCATION: US 264 FROM APPROXIMATELY 800' EAST OF SR 1311
(ASBURY CHURCH RD.) TO 0.45 MILES WEST OF NC 32
NEAR BEAUFORT COMMUNITY COLLEGE IN WASHINGTON.**

**TYPE OF WORK: RESURFACING, WIDENING, DRAINAGE,
PAVEMENT MARKING AND SIGNING**

INDEX OF SHEETS

SHEET NO.	TITLE
TMP-01	TITLE SHEET, VICINITY MAP, AND INDEX OF SHEETS
TMP-01A	LIST OF APPLICABLE ROADWAY STANDARD DRAWINGS AND LEGEND
TMP-02	TRANSPORTATION OPERATIONS PLAN: (MANAGEMENT STRATEGIES, GENERAL NOTES, AND LOCAL NOTES)
TMP-03	TEMPORARY TRAFFIC CONTROL PHASING
TMP-04 THRU 11	PHASE I DETAIL
TMP-12 THRU 17	PHASE II DETAIL

SHEET NO.
TMP-01

W-5702G\W-5702R

TIP PROJECT:

**DOCUMENT NOT CONSIDERED FINAL
UNLESS ALL SIGNATURES COMPLETED**

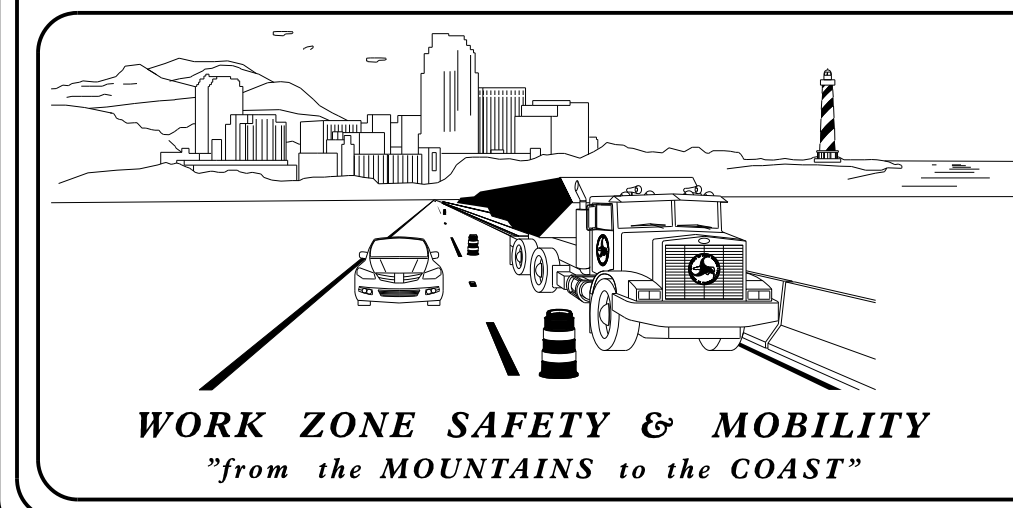

PLANS PREPARED BY:

BOB MAY, P.E.

D. ALLEN HAYES, E.I.

NCDOT CONTACTS:

LARRY L. JONES, P.E.
DIVISION PROJECT ENGINEER

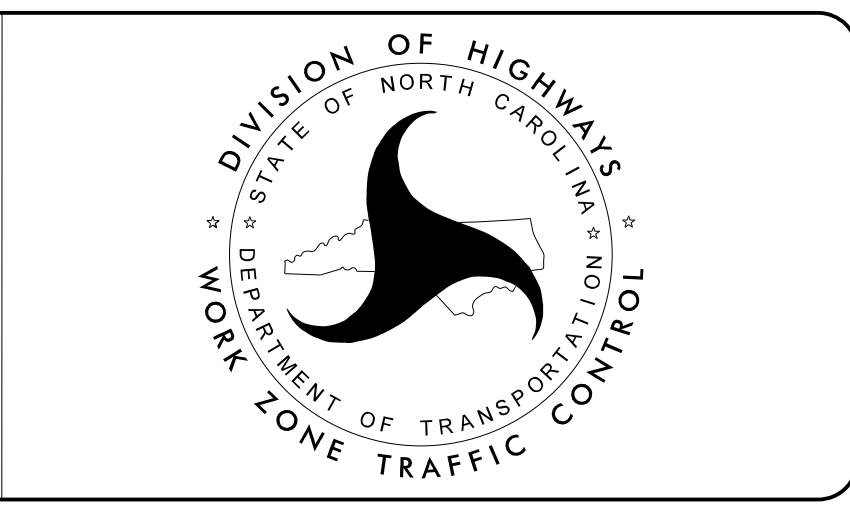

WETHERILL ENGINEERING

1223 Jones Franklin Rd.
Raleigh, N.C. 27606
License No. F-63377
Bus: 919 851 8077
Fax: 919 851 8107

APPROVED: *Bob L. May*

DATE: 12/11/2023

SEAL

TRANSPORTATION PLANNING/DESIGN - BRIDGE/STRUCTURE DESIGN
CIVIL/SITE DESIGN - GIS/GPS - CONSTRUCTION OBSERVATION

I:\6\2023
P:\2019\915101_W-5702R_Superstreet+Traffic\Traffic Design\Design\Pre-Let\Plan\WZTC\Sheets\W-5702GR_TMP_01_Title.dgn
User:AHayes

ROADWAY STANDARD DRAWINGS

THE FOLLOWING ROADWAY STANDARDS AS SHOWN IN "ROADWAY STANDARD DRAWINGS" - N.C. DEPARTMENT OF TRANSPORTATION - RALEIGH, N.C., DATED JANUARY 2018 ARE APPLICABLE TO THIS PROJECT AND BY REFERENCE HEREBY ARE CONSIDERED A PART OF THESE PLANS:

STD. NO.	TITLE
1101.01	WORK ZONE WARNING SIGNS
1101.02	TEMPORARY LANE CLOSURES
1101.04	TEMPORARY SHOULDER CLOSURES
1101.05	WORK ZONE VEHICLE ACCESSES
1101.11	TRAFFIC CONTROL DESIGN TABLES
1110.01	STATIONARY WORK ZONE SIGNS
1110.02	PORTABLE WORK ZONE SIGNS
1115.01	FLASHING ARROW BOARDS
1130.01	DRUMS
1135.01	CONES
1145.01	BARRICADES
1150.01	FLAGGING DEVICES
1160.01	TEMPORARY CRASH CUSHION
1165.01	TRUCK MOUNTED ATTENUATOR
1180.01	SKINNY - DRUMS
1205.01	PAVEMENT MARKINGS - LINE TYPES AND OFFSETS
1205.02	PAVEMENT MARKINGS - TWO LANE AND MULTILANE ROADWAYS
1205.04	PAVEMENT MARKINGS - INTERSECTIONS
1205.05	PAVEMENT MARKINGS - TURN LANES
1205.08	PAVEMENT MARKINGS - SYMBOLS AND WORD MESSAGES
1205.09	PAVEMENT MARKINGS - PAINTED ISLANDS
1205.11	PAVEMENT MARKINGS - RAILROAD CROSSINGS
1205.15	PAVEMENT MARKINGS - SUPERSTREETS
1250.01	RAISED PAVEMENT MARKERS - INSTALLATION SPACING
1251.01	RAISED PAVEMENT MARKERS - (PERMANENT AND TEMPORARY)

LEGEND

GENERAL

- DIRECTION OF TRAFFIC FLOW
- EXIST. PVMT.
- NORTH ARROW
- PROPOSED PVMT.
- WORK AREA

PAVEMENT MARKINGS

- EXISTING LINES
- TEMPORARY LINES

TRAFFIC CONTROL DEVICES

- DRUM
- SKINNY DRUM

PAVEMENT MARKING SYMBOLS

- PAVEMENT MARKING SYMBOLS

TEMPORARY PAVEMENT MARKING

SYMBOL	DESCRIPTION	PAY ITEM
P1	WHITE SOLID EDGE LINE	PAINT
P3	10 FT. - 30 FT./SP WHITE SKIP	PAINT
P4	3 FT. - 9 FT./SP WHITE MINISKIP	PAINT
P77	U-TURN ARROW	PAINT PAVEMENT MARKING SYMBOLS

I:\6\2023
 P:\2019\915101.W-5702R-Superstreet+Traffic\Traffic\Design\Pre-Let\Plan\WZTC\Sheets\W-5702GR-TMP_01A_Legend.dgn
 User: AHayes

 1223 Jones Franklin Rd. Raleigh, N.C. 27606 License No. F-0377 Bus: 919 851 8077 Fax: 919 851 8107	APPROVED: DATE: 12/11/2023			LIST OF APPLICABLE ROADWAY STANDARD DRAWINGS, AND LEGEND
TRANSPORTATION PLANNING/DESIGN - BRIDGE/STRUCTURE DESIGN CIVIL/SITE DESIGN - GIS/GPS - CONSTRUCTION OBSERVATION DOCUMENT NOT CONSIDERED FINAL UNLESS ALL SIGNATURES COMPLETED				

PROJ. REFERENCE NO.	SHEET NO.
W-5702G/W-5702R	TMP-02

GENERAL NOTES

CHANGES MAY BE REQUIRED WHEN PHYSICAL DIMENSIONS IN THE DETAIL DRAWINGS, STANDARD DETAILS, AND ROADWAY DETAILS ARE NOT ATTAINABLE TO MEET FIELD CONDITIONS OR RESULT IN DUPLICATE OR UNDESIRE OVERLAPPING OF DEVICES. MODIFICATION MAY INCLUDE: MOVING, SUPPLEMENTING, COVERING, OR REMOVAL OF DEVICES AS DIRECTED BY THE ENGINEER.

THE FOLLOWING GENERAL NOTES APPLY AT ALL TIMES FOR THE DURATION OF THE CONSTRUCTION PROJECT EXCEPT WHEN OTHERWISE NOTED IN THE PLAN OR DIRECTED BY THE ENGINEER.

TIME RESTRICTIONS

A) DO NOT CLOSE OR NARROW TRAVEL LANES AS FOLLOWS:

ROAD NAME	DAY AND TIME RESTRICTIONS
1. -EL-	6:00 A.M. - 8:30 A.M. 4:30 P.M. - 7:00 P.M. MONDAY - FRIDAY

B) DO NOT CLOSE OR NARROW TRAVEL LANES DURING HOLIDAYS AND SPECIAL EVENTS AS FOLLOWS:

ROAD NAME

1. -EL- US 264

HOLIDAY

- FOR ANY UNEXPECTED OCCURRENCE THAT CREATES UNUSUALLY HIGH TRAFFIC VOLUMES, AS DIRECTED BY THE ENGINEER.
- FOR NEW YEAR'S, BETWEEN THE HOURS OF 6:00 A.M. DECEMBER 31st TO 7:00 P.M. JANUARY 2ND. IF NEW YEAR'S DAY IS ON A FRIDAY, SATURDAY, SUNDAY, OR MONDAY THEN UNTIL 7:00 P.M. THE FOLLOWING TUESDAY.
- FOR EASTER, BETWEEN THE HOURS OF 6:00 A.M. THURSDAY AND 7:00 P.M. MONDAY.
- FOR MEMORIAL DAY, BETWEEN THE HOURS OF 6:00 A.M. FRIDAY TO 7:00 P.M. TUESDAY.
- FOR INDEPENDENCE DAY, BETWEEN THE HOURS OF 6:00 A.M. THE DAY BEFORE INDEPENDENCE DAY AND 7:00 P.M. THE DAY AFTER INDEPENDENCE DAY.

IF INDEPENDENCE DAY IS ON A FRIDAY, SATURDAY, SUNDAY OR MONDAY THEN BETWEEN THE HOURS OF 6:00 A.M. THE THURSDAY BEFORE INDEPENDENCE DAY AND 7:00 P.M. THE TUESDAY AFTER INDEPENDENCE DAY.
- FOR LABOR DAY, BETWEEN THE HOURS OF 6:00 A.M. FRIDAY AND 7:00 P.M. TUESDAY.
- FOR THANKSGIVING DAY, BETWEEN THE HOURS OF 6:00 A.M. TUESDAY TO 7:00 P.M. MONDAY.
- FOR CHRISTMAS, BETWEEN THE HOURS OF 6:00 A.M. THE FRIDAY BEFORE THE WEEK OF CHRISTMAS DAY AND 7:00 P.M. THE FOLLOWING TUESDAY AFTER THE WEEK OF CHRISTMAS.

C) DO NOT CONDUCT ANY HAULING OPERATIONS AGAINST THE FLOW OF TRAFFIC OF AN OPEN TRAVELWAY UNLESS THE HAULING OPERATION IS PROTECTED BY BARRIER OR GUARDRAIL OR AS DIRECTED BY THE ENGINEER.

LANE AND SHOULDER CLOSURE REQUIREMENTS

- REMOVE LANE CLOSURE DEVICES FROM THE LANE WHEN WORK IS NOT BEING PERFORMED BEHIND THE LANE CLOSURE OR WHEN A LANE CLOSURE IS NO LONGER NEEDED OR AS DIRECTED BY THE ENGINEER.
- WHEN PERSONNEL AND/OR EQUIPMENT ARE WORKING WITHIN 15 FT OF AN OPEN TRAVEL LANE, CLOSE THE NEAREST OPEN SHOULDER USING ROADWAY STANDARD DRAWING NO. 1101.04 UNLESS THE WORK AREA IS PROTECTED BY BARRIER OR GUARDRAIL OR A LANE CLOSURE IS INSTALLED.
- WHEN PERSONNEL AND/OR EQUIPMENT ARE WORKING ON THE SHOULDER ADJACENT TO AN UNDIVIDED FACILITY AND WITHIN 5 FT OF AN OPEN TRAVEL LANE, CLOSE THE NEAREST OPEN TRAVEL LANE USING ROADWAY STANDARD DRAWING NO. 1101.02 UNLESS THE WORK AREA IS PROTECTED BY BARRIER OR GUARDRAIL.

WHEN PERSONNEL AND/OR EQUIPMENT ARE WORKING ON THE SHOULDER ADJACENT TO A DIVIDED FACILITY AND WITHIN 10 FT OF AN OPEN TRAVEL LANE, CLOSE THE NEAREST OPEN TRAVEL LANE USING ROADWAY STANDARD DRAWING NO. 1101.02 UNLESS THE WORK AREA IS PROTECTED BY BARRIER OR GUARDRAIL.

- WHEN PERSONNEL AND/OR EQUIPMENT ARE WORKING WITHIN A LANE OF TRAVEL OF AN UNDIVIDED OR DIVIDED FACILITY, CLOSE THE LANE ACCORDING TO THE TRAFFIC CONTROL PLANS, ROADWAY STANDARD DRAWINGS, OR AS DIRECTED BY THE ENGINEER. CONDUCT THE WORK SO THAT ALL PERSONNEL AND/OR EQUIPMENT REMAIN WITHIN THE CLOSED TRAVEL LANE.
- DO NOT WORK SIMULTANEOUSLY WITHIN 15 FT ON BOTH SIDES OF AN OPEN TRAVELWAY, RAMP, OR LOOP WITHIN THE SAME LOCATION UNLESS PROTECTED WITH GUARDRAIL OR BARRIER.
- DO NOT INSTALL MORE THAN 1 MILE OF LANE CLOSURE ON US 264 MEASURED FROM THE BEGINNING OF THE MERGE TAPER TO THE END OF THE LANE CLOSURE.
- DO NOT INSTALL MORE THAN ONE LANE CLOSURE IN ANY ONE DIRECTION ON US 264.

PAVEMENT EDGE DROP OFF REQUIREMENTS

- BACKFILL AT A 6:1 SLOPE UP TO THE EDGE AND ELEVATION OF EXISTING PAVEMENT IN AREAS ADJACENT TO AN OPENED TRAVEL LANE THAT HAS AN EDGE OF PAVEMENT DROP-OFF AS FOLLOWS:

BACKFILL DROP-OFFS THAT EXCEED 2 INCHES ON ROADWAYS WITH POSTED SPEED LIMITS OF 45 MPH OR GREATER.

BACKFILL DROP-OFFS THAT EXCEED 3 INCHES ON ROADWAYS WITH POSTED SPEED LIMITS LESS THAN 45 MPH.

BACKFILL WITH SUITABLE COMPACTED MATERIAL, AS APPROVED BY THE ENGINEER, AT NO EXPENSE TO THE DEPARTMENT.
- DO NOT EXCEED A DIFFERENCE OF 2 INCHES IN ELEVATION BETWEEN OPEN LANES OF TRAFFIC FOR NOMINAL LIFTS OF 1.5 INCHES. INSTALL ADVANCE WARNING "UNEVEN LANES" SIGNS (W8-11) 500 FT/MI IN ADVANCE AND A MINIMUM OF EVERY HALF MILE THROUGHOUT THE UNEVEN AREA.

TRAFFIC PATTERN ALTERATIONS

- NOTIFY THE ENGINEER THIRTY (30) CALENDAR DAYS PRIOR TO ANY TRAFFIC PATTERN ALTERATION.

SIGNING

- INSTALL ADVANCE WORK ZONE WARNING SIGNS WHEN WORK IS WITHIN 40 FT FROM THE EDGE OF TRAVEL LANE AND NO MORE THAN THREE (3) DAYS PRIOR TO THE BEGINNING OF CONSTRUCTION.
- ENSURE ALL NECESSARY SIGNING IS IN PLACE PRIOR TO ALTERING ANY TRAFFIC PATTERN.
- INSTALL BLACK ON ORANGE "DIP" SIGNS (W8-2) AND/OR "BUMP" SIGNS (W8-1) 500 FT IN ADVANCE OF THE UNEVEN AREA, OR AS DIRECTED BY THE ENGINEER.

TRAFFIC CONTROL DEVICES

- WHEN LANE CLOSURES ARE NOT IN EFFECT SPACE CHANNELIZING DEVICES IN WORK AREAS NO GREATER IN FEET THAN TWICE THE POSTED SPEED LIMIT (MPH) EXCEPT, 10 FT ON-CENTER IN RADIUS, AND 3 FT OFF THE EDGE OF AN OPEN TRAVELWAY. REFER TO STANDARD SPECIFICATIONS FOR ROADS AND STRUCTURES SECTIONS 1130 (DRUMS), 1135 (CONES) AND 1180 (SKINNY DRUMS) FOR ADDITIONAL REQUIREMENTS.
- PLACE ADDITIONAL SETS OF THREE CHANNELIZING DEVICES PERPENDICULAR TO THE EDGE OF TRAVELWAY ON 500 FT CENTERS WHEN UNOPENED LANES ARE CLOSED TO TRAFFIC.

PAVEMENT MARKINGS AND MARKERS

- INSTALL TEMPORARY PAVEMENT MARKINGS AND TEMPORARY PAVEMENT MARKERS ON INTERIM LAYERS OF PAVEMENT AS FOLLOWS:

ROAD NAME	MARKING	MARKER
1. US 264	PAINT	NONE

- PLACE ONE APPLICATION OF PAINT FOR TEMPORARY TRAFFIC PATTERNS. PLACE A SECOND APPLICATION OF PAINT SIX (6) MONTHS AFTER THE INITIAL APPLICATION AND EVERY SIX MONTHS AS DIRECTED BY THE ENGINEER.
- TIE PROPOSED PAVEMENT MARKING LINES TO EXISTING PAVEMENT MARKING LINES.
- REMOVE/REPLACE ANY CONFLICTING/DAMAGED PAVEMENT MARKINGS AND MARKERS BY THE END OF EACH DAY'S OPERATION.
- TRACE THE PROPOSED MONOLITHIC ISLAND LOCATIONS WITH PROPER COLOR PAVEMENT MARKINGS PRIOR TO INSTALLATION. PLACE DRUMS TO DELINEATE ANY PROPOSED MONOLITHIC ISLANDS BEFORE INSTALLATION.

MISCELLANEOUS

- LAW ENFORCEMENT MAY BE USED TO MAINTAIN TRAFFIC THROUGH THE WORK AREA AND/OR INTERSECTIONS AS DIRECTED BY THE ENGINEER.
- IN THE EVENT A TIE-IN CANNOT BE MADE IN ONE DAY'S TIME, BRING THE TIE-IN AREA TO AN APPROPRIATE ROADWAY ELEVATION AS DETERMINED BY THE ENGINEER. PLACE BLACK ON ORANGE "LOOSE GRAVEL" SIGNS (W8-7) AND BLACK ON ORANGE "PAVEMENT ENDS" SIGNS (W8-3) 500 FT AND 500 FT RESPECTIVELY IN ADVANCE OF THE UNEVEN AREAS. USE DRUMS TO DELINEATE THE EDGE OF ROADWAY ALONG UNPAVED AREAS.
- ALL STATIONS ARE CONSIDERED +/- UNLESS OTHERWISE SHOWN ON THE PLANS.
- WHEN CONSTRUCTING DRAINAGE STRUCTURES ADJACENT TO TRAFFIC, INSTALL TEMPORARY STEEL PLATES, AS DIRECTED BY THE ENGINEER. THE CONTRACTOR MAY WORK EACH LOCATION INDEPENDENTLY OR CONCURRENTLY, UNLESS OTHERWISE DIRECTED BY THE ENGINEER. WORK IN A CONTINUOUS MANNER TO PERFORM THE WORK IN THE FOLLOWING SEQUENCE, STEPS '1' THRU '5'.
 - CLOSE THE APPROPRIATE TRAVEL LANE TO TRAFFIC USING ROADWAY STANDARD DRAWING NO. 1101.02.
 - CONSTRUCT PROPOSED STRUCTURE OR INSTALL PRE-CAST DRAINAGE STRUCTURE AS SHOWN IN THE CONSTRUCTION PLANS AND COVER WITH STEEL PLATES TO PROTECT STRUCTURE DURING CURING.
 - OPEN TRAVEL LANE TO EXISTING TRAFFIC PATTERN BY THE END OF EACH WORK PERIOD.
 - WHEN PROPERLY CURED, CLOSE THE APPROPRIATE TRAVEL LANE USING ROADWAY STANDARD DRAWING NO. 1101.02. BACKFILL & PAVE, IF REQUIRED, UP TO THE EDGE AND ELEVATION OF EXISTING PAVEMENT (SEE CONSTRUCTION PLANS).
 - OPEN TRAVEL LANE TO EXISTING TRAFFIC PATTERN BY THE END OF THE WORK PERIOD.
- THE CONTRACTOR SHALL MAINTAIN ACCESS TO RESIDENTS AND BUSINESSES DURING CONSTRUCTION.

LOCAL NOTES

NOTIFY BEAUFORT COUNTY EMERGENCY SERVICES AND BEAUFORT COUNTY COMMUNITY COLLEGE AT LEAST THIRTY DAYS PRIOR TO CONSTRUCTION.
CALL 811 BEFORE YOU DIG.

MANAGEMENT STRATEGIES



THE FOLLOWING LISTED WORK ZONE STRATEGIES ARE RECOMMENDED FOR INCLUSION WITHIN THIS TRANSPORTATION MANAGEMENT PLAN (TMP).

RECOMMENDED STRATEGIES:

TRAFFIC MANAGEMENT STRATEGIES:
LANE SHIFTS OR CLOSURES
SHOULDER CLOSURES
ONE-LANE, TWO WAY OPERATION (FLAGGING)
WORK HOUR RESTRICTIONS FOR PEAK TRAVEL

TRAFFIC / INCIDENT MANAGEMENT & SPEED ENFORCEMENT STRATEGIES:
DEDICATED (PAID) LAW ENFORCEMENT

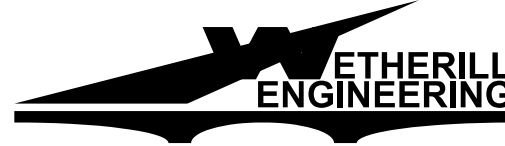
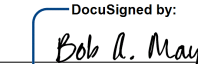
I:\2\2023
P:\2019\GIS\101.W-5702R-Superstreet\Traffic\Traffic Design\Design\Pre-Let\Plan\WZTC\Sheets\W-5702GR-TMP-02-GeneralNotes.dgn
User:AHayes

 1223 Jones Franklin Rd. Raleigh, N.C. 27606 License No. F-0377 Bus: 919 851 8077 Fax: 919 851 8107	APPROVED:  DATE: 12/11/2023	 DOCUMENT NOT CONSIDERED FINAL UNLESS ALL SIGNATURES COMPLETED		TRANSPORTATION OPERATIONS PLAN: (MANAGEMENT STRATEGIES AND GENERAL NOTES), AND TEMPORARY TRAFFIC CONTROL PHASING
---	---	---	---	--

NOTES:

BEFORE BEGINNING CONSTRUCTION, THE CONTRACTOR SHALL INSTALL WORK ZONE ADVANCE WARNING SIGNS PER RSD 1101.01 ON -EL-, -EY- AND -EY1-.

CONTRACTOR SHALL MAINTAIN VEHICULAR ACCESS TO ALL RESIDENCES, BUSINESSES AND SIDE STREETS THROUGHOUT THE DURATION OF THE CONTRACT UNLESS OTHERWISE NOTED IN PHASING OR DIRECTED BY THE ENGINEER. FOLLOW THE TIME RESTRICTIONS AND REQUIREMENTS SHOWN IN THE GENERAL NOTES AND AS DIRECTED BY THE ENGINEER.

COMPLETE ANY PROPOSED WORK IN SUCH A MANNER THAT PONDING OF WATER WILL NOT OCCUR IN THE TRAVEL LANE. STEEL PLATES MAY BE USED TEMPORARILY OVER DRAINAGE FEATURES ADJACENT TO TRAVEL WAY.

PAVE PROPOSED CONSTRUCTION, UP TO BUT NOT INCLUDING THE FINAL LAYER OF SURFACE COURSE IN ALL PHASES UNTIL STATED TO INSTALL FINAL LAYER.

THE TERM "RSD" DENOTES ROADWAY STANDARD DRAWING.

PHASE I

***REFER TO SHEETS TMP-4 THRU TMP-10 FOR DETAILS
 ***STEPS 1 THRU 2 MAY BE COMPLETED IN ANY ORDER BUT NOT SIMULTANEOUSLY. ***

STEP 1: USING DRUMS AND FLAGGERS AS NEEDED PER RSD 1101.02 SHEET 3 OF 14, CONTRACTOR SHALL CLOSE THE RIGHT LANE OF US-264 EASTBOUND.

CONSTRUCT PROPOSED WIDENING FOR BULB-OUTS AND ASSOCIATED DRAINAGE AT THE FOLLOWING LOCATIONS:
 -EL- FROM STA. 18+07 +/- TO STA. 20+80 +/- RT (W-5702R)
 -EL- FROM STA. 32+80 +/- TO STA. 35+61 +/- RT (W-5702R)
 -EL- FROM STA. 11+46 +/- TO STA. 14+40 +/- RT (W-5702G)
 -EL- FROM STA. 39+76 +/- TO STA. 42+25 +/- RT (W-5702G)

CONTRACTOR SHALL ALSO INSTALL DRIVEWAY PIPES REPLACEMENTS AND ADJUST DRAINAGE STRUCTURES AS SHOWN IN TMP-4 THRU TMP-10.

STEP 2: USING DRUMS AND FLAGGERS AS NEEDED PER RSD 1101.02 SHEET 3 OF 14, CONTRACTOR SHALL CLOSE THE RIGHT LANE OF US-264 WESTBOUND.

CONSTRUCT PROPOSED WIDENING FOR BULB-OUTS, ASSOCIATED DRAINAGE AND RIGHT TURN LANES AT THE FOLLOWING LOCATIONS:
 -EL- FROM STA. 43+28 +/- TO STA. 45+94 +/- LT (W-5702R)
 -EL- FROM STA. 22+35 +/- TO STA. 28+70 +/- LT (W-5702G)
 -EL- FROM STA. 35+51 +/- TO STA. 38+20 +/- LT (W-5702G)
 -EL- FROM STA. 49+83 +/- TO STA. 52+50 +/- LT (W-5702G)

CONTRACTOR SHALL ALSO INSTALL DRIVEWAY PIPES REPLACEMENTS AS SHOWN IN TMP-4 THRU TMP-10.

PHASE II

REFER TO SHEETS TMP-11 THRU TMP-17 FOR DETAILS

CHANGEABLE MESSAGE SIGNS (CMS) SHALL BE USED ON -EL- (US-264) AND -EY- (NECK ROAD) TO NOTIFY ON NEW TRAFFIC PATTERN AS NEEDED DURING STEP 3.

STEP 1: USING DRUMS AND FLAGGERS AS NEEDED PER RSD 1101.02 SHEETS 3 AND 7 OF 14, CONTRACTOR SHALL REMOVE THE EXISTING PAVEMENT MARKINGS IN THE EASTBOUND AND WESTBOUND THROUGH LANES OF -EL- US 264. THE CONTRACTOR SHALL INSTALL TEMPORARY PAVEMENT MARKINGS AND MARKERS. NARROW THE THROUGH LANES TO 11 FEET AS SHOWN IN TMP-8 THRU TMP-11.

THE CONTRACTOR SHALL COMPLETE PHASE II, STEP 2 WITHIN 60 CONSECUTIVE CALENDAR DAYS. SEE INTERMEDIATE CONTRACT TIME AND LIQUIDATED DAMAGES.

STEP 2: USING DRUMS AND FLAGGERS AS NEEDED PER RSD 1101.02 SHEET 3 OF 14, CONTRACTOR SHALL TEMPORARILY CLOSE THE LEFT LANE OF US-264 EASTBOUND AND THE LEFT LANE OF US-264 WESTBOUND.

CONSTRUCT THE ASSOCIATED MEDIAN DRAINAGE AT THE FOLLOWING LOCATIONS:
 -EL- FROM STA. 11+45 +/- TO STA. 52+35 +/- (W-5702G)
 -EL- FROM STA. 13+34 +/- TO STA. 52+65 +/- (W-5702R)

THE CONTRACTOR SHALL USE DRUMS AND/OR SKINNY DRUMS TO MAINTAIN ACCESS FOR BUSINESSES AND RESIDENTS DURING CONSTRUCTION. CONTRACTOR SHALL BACKFILL AND PAVE, IF REQUIRED, UP TO THE EDGE AND ELEVATION OF THE EXISTING PAVEMENT.

STEP 3: USING DRUMS AND FLAGGERS AS NEEDED PER RSD 1101.02 SHEET 3 OF 14, CONTRACTOR SHALL TEMPORARILY CLOSE THE LEFT LANE OF US-264 EASTBOUND AND THE LEFT LANE OF US-264 WESTBOUND.

REMOVE THE EXISTING CENTER TURN LANE MARKINGS AND/OR WEDGE -EL- AS NEEDED. CONSTRUCT THE MEDIAN ISLANDS FROM:
 *-EL- FROM STA. 11+45 +/- TO STA. 52+35 +/- (W-5702G) *
 *-EL- FROM STA. 13+34 +/- TO STA. 52+65 +/- (W-5702R) *

THE CONTRACTOR SHALL STAGE THE WORK OF STEP 3 TO MAINTAIN ACCESS FOR BUSINESSES AND RESIDENTS. CONTRACTOR SHALL USE CMSs, DRUMS AND/OR SKINNY DRUMS. THE CONTRACTOR MAY USE THE U-TURN BULBS PROVIDED THAT TIME FOR PROPER CURING OF THE MEDIAN AND THE SIGNAGE OF TRAFFIC MOVEMENTS IS HANDLED BY CMSs AND/OR PERMANENT SIGNING.

STEP 4: USING DRUMS AND FLAGGERS AS NEEDED PER RSD 1101.02 SHEETS 1 AND 3 OF 14, CONTRACTOR SHALL COMPLETE THE FOLLOWING WORK:

REMOVE THE EXISTING ISLANDS AND CONSTRUCT PROPOSED ISLANDS ON ALL -Y- LINES
 INSTALL ANY REMAINING TEMPORARY PAVEMENT MARKINGS ON PROJECT AS NEEDED

PHASE III



***UNTIL DIRECTED, TRAFFIC WILL REMAIN IN THE SAME PATTERN AS PHASE II. ***

STEP 1: THE CONTRACTOR SHALL OPEN TRAFFIC TO U-TURN PATTERN FOR BULB-OUTS.

STEP 2: CONTRACTOR, USING TEMPORARY LANE CLOSURES PER RSD 1101.02 SHEET 1, 3, 11, AND 12 OF 14 AND FLAGGERS AS NEEDED, SHALL COMPLETE STEPS A THRU C. WORK IN STEPS A THRU C MAY BE PERFORMED SIMULTANEOUSLY.
 A: SHALL COMPLETE ANY NECESSARY REMAINING ROADWAY OR DRAINAGE WORK.
 B: SHALL PAVE THE FINAL SURFACE COURSE ON -EL-, -EY-, -EY1-.
 C: SHALL PLACE FINAL PAVEMENT MARKINGS ON -EL-, -EY-, -EY1- PER PMP-4 THRU PMP-7.

STEP 3: AT THE CONCLUSION OF ALL WORK, CONTRACTOR SHALL PLACE TRAFFIC IN FINAL PATTERN AND REMOVE ALL TRAFFIC CONTROL DEVICES FROM PROJECT.

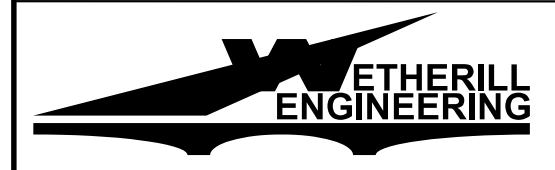
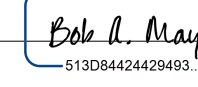
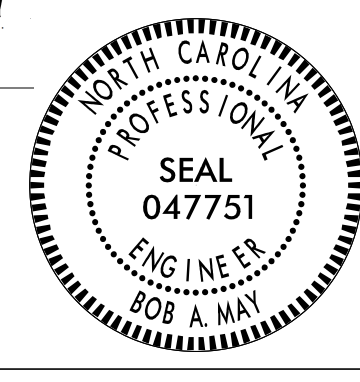
12/11/2023 10:51:01 AM W-5702R_Superstreet+Traffic\Traffic\Traffic Design\Design\Pre-Let\Plan\WZTC\Sheets\W-5702GR_TMP_03_Phasing.dgn User:AHayes

 <p>1223 Jones Franklin Rd. Raleigh, N.C. 27606 License No. F-0377 Bus: 919 851 8077 Fax: 919 851 8107</p> <p>TRANSPORTATION PLANNING/DESIGN - BRIDGE/STRUCTURE DESIGN CIVIL/SITE DESIGN - GIS/GPS - CONSTRUCTION OBSERVATION</p>	<p>APPROVED:  DATE: 12/11/2023</p>			<p>PHASING</p>
DOCUMENT NOT CONSIDERED FINAL UNLESS ALL SIGNATURES COMPLETED				

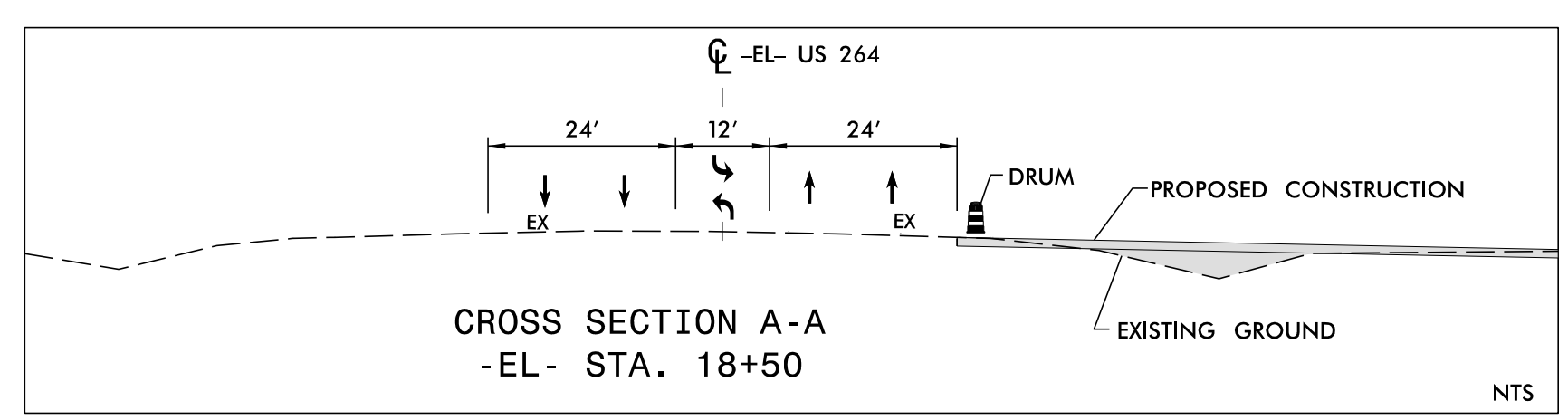
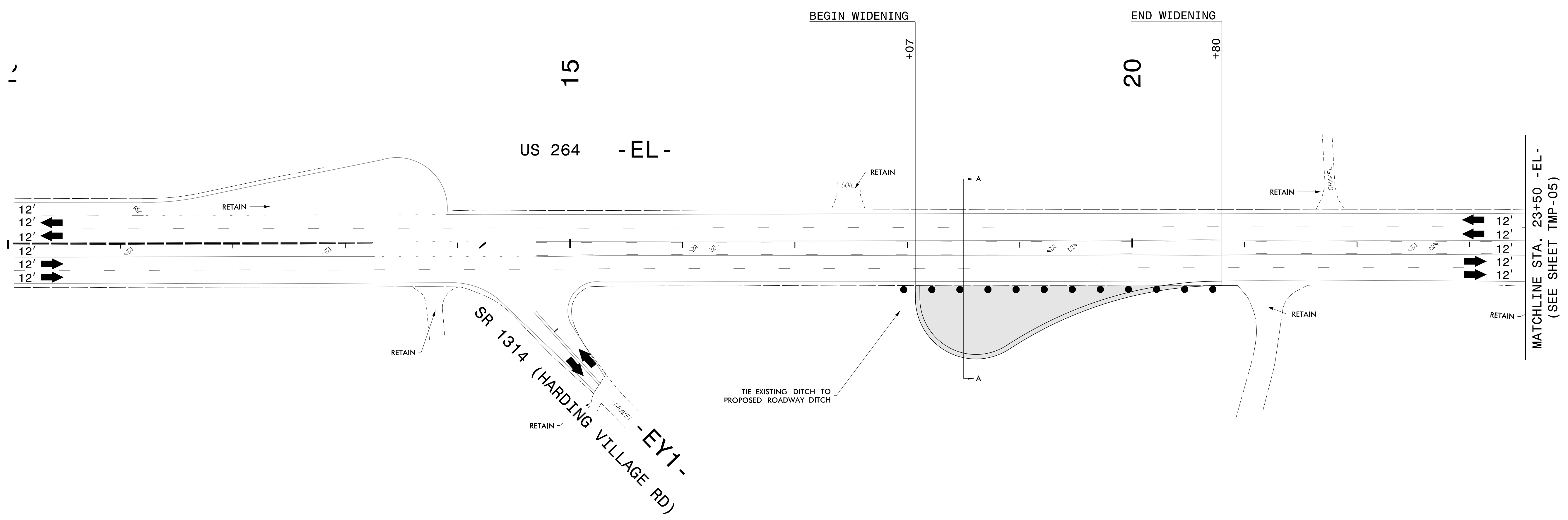
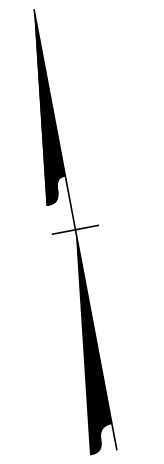

12/11/2023
 P:\2019\915101_W-5702R_Superstreet\Traffic\Design\Pre-Let\Plan\WZTC\Sheets\W-5702GR_TMP_04_Phl.cgn
 User: AHayes

1223 Jones Franklin Rd.
 Raleigh, N.C. 27606
 License No. F-0377
 Bus: 919 851 8077
 Fax: 919 851 8107

TRANSPORTATION PLANNING/DESIGN - BRIDGE/STRUCTURE DESIGN
 CIVIL/SITE DESIGN - GIS/GPS - CONSTRUCTION OBSERVATION

APPROVED: *Ede A. May*
DocuSigned by:
Ede A. May
513084424429463
 DATE: 12/11/2023

**DOCUMENT NOT CONSIDERED FINAL
 UNLESS ALL SIGNATURES COMPLETED**

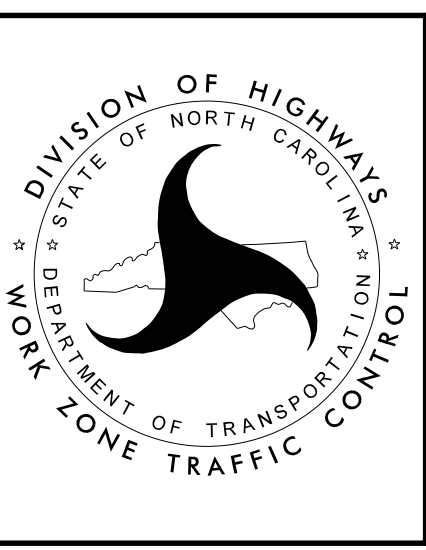

PHASE I DETAIL

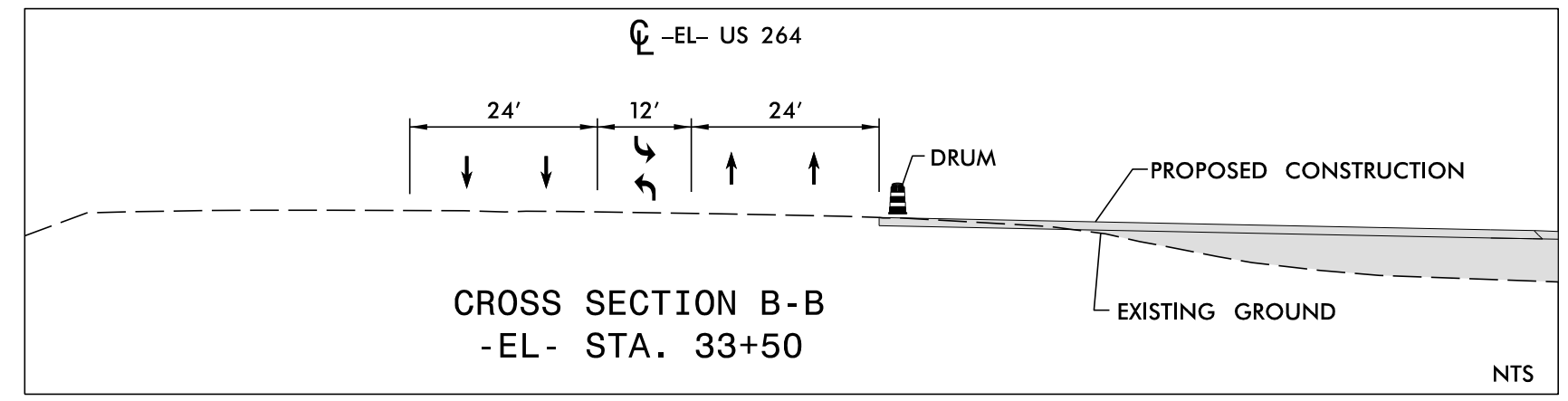
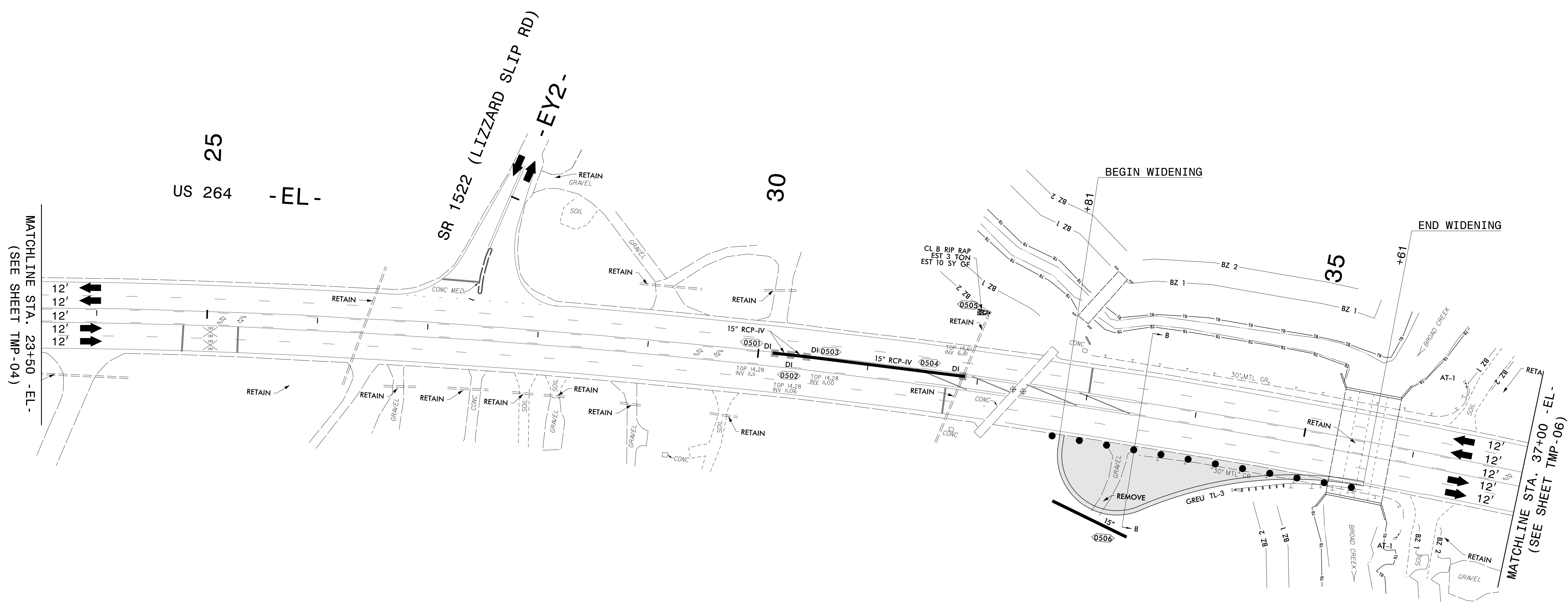
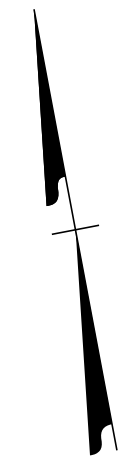

12/11/2023
 P:\2019\915101_W-5702R_Superstreet\Traffic\Design\Pre-Let\Plan\WZTC\Sheets\W-5702GR_TMP_05_Phl.cgn
 User: AHayes

ETHERILL ENGINEERING
 1223 Jones Franklin Rd.
 Raleigh, N.C. 27606
 License No. F-0377
 Bus: 919 851 8077
 Fax: 919 851 8107

APPROVED: *Bob A. May*
DocuSigned by:
513D8424429493

DATE: 12/11/2023

**DOCUMENT NOT CONSIDERED FINAL
UNLESS ALL SIGNATURES COMPLETED**

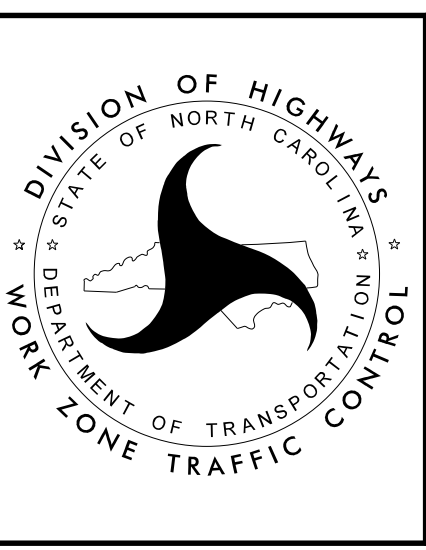

PHASE I DETAIL

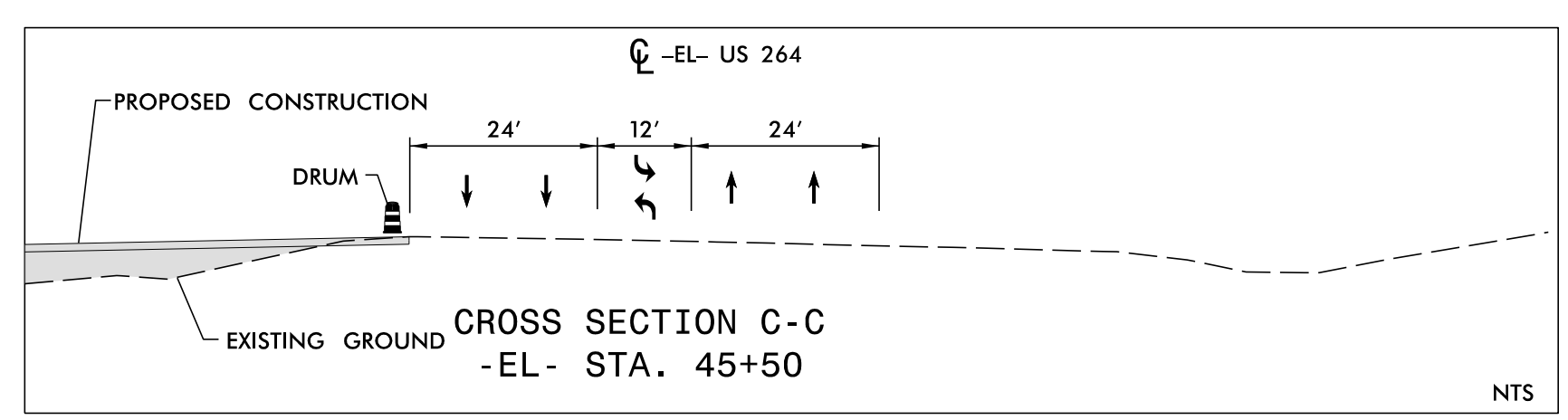
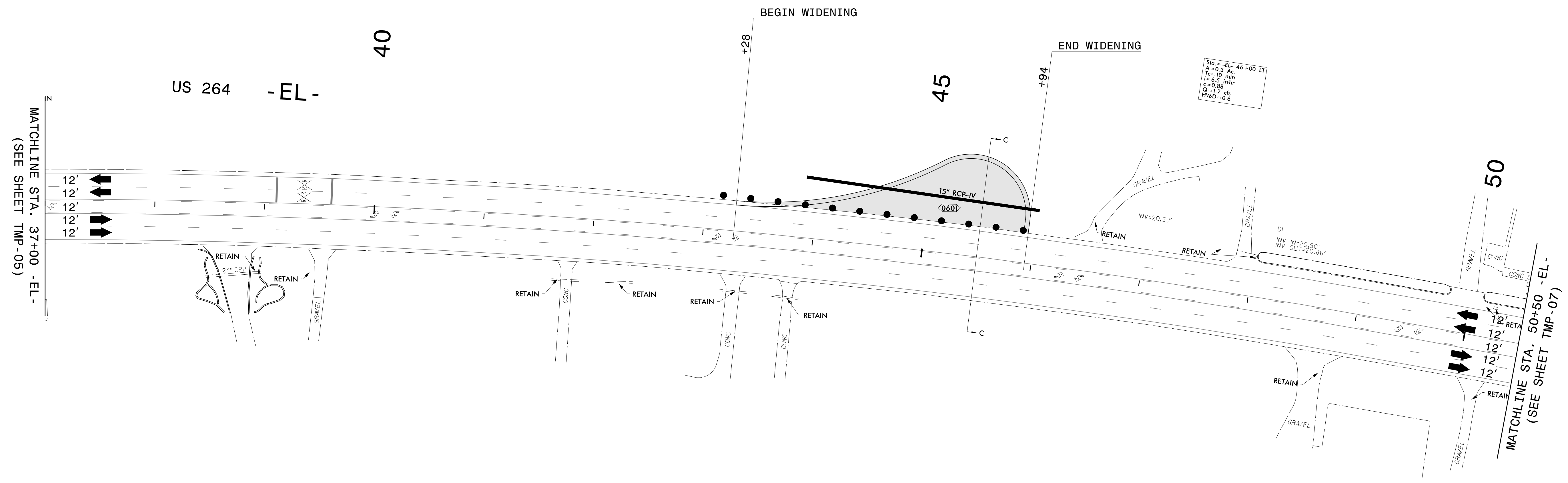
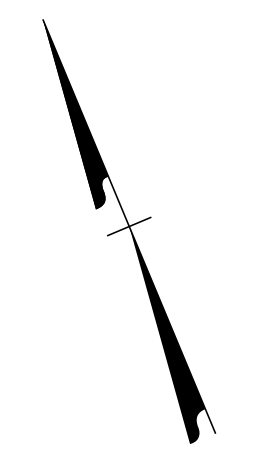

12/11/2023
 P:\2019\915101_W-5702R_Superstreet\Traffic\Design\Pre-Let\Plan\WZTC\Sheets\W-5702GR_TMP_06_Philcgn
 User: AHayes

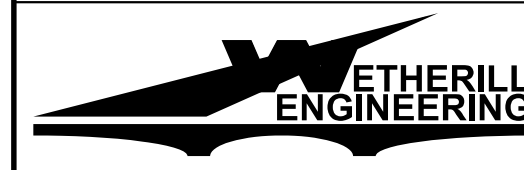
 1223 Jones Franklin Rd.
 Raleigh, N.C. 27606
 License No. F-0377
 Bus: 919 851 8077
 Fax: 919 851 8107

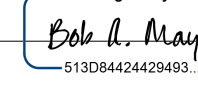
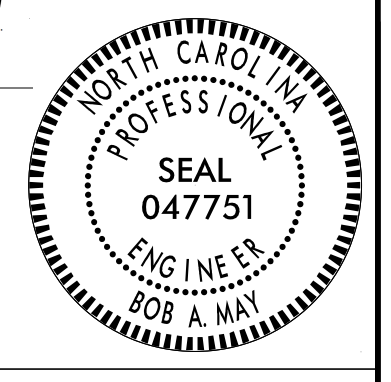
APPROVED: 
 DATE: 12/11/2023

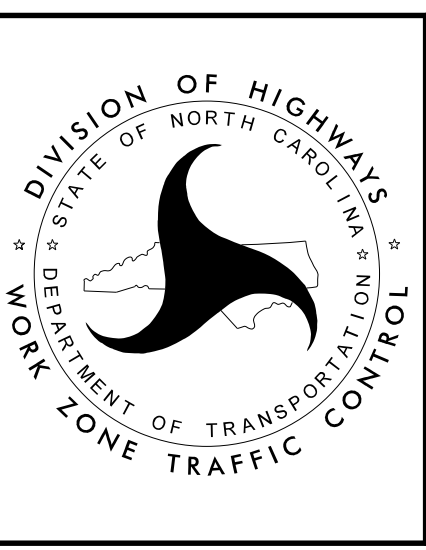
**DOCUMENT NOT CONSIDERED FINAL
 UNLESS ALL SIGNATURES COMPLETED**

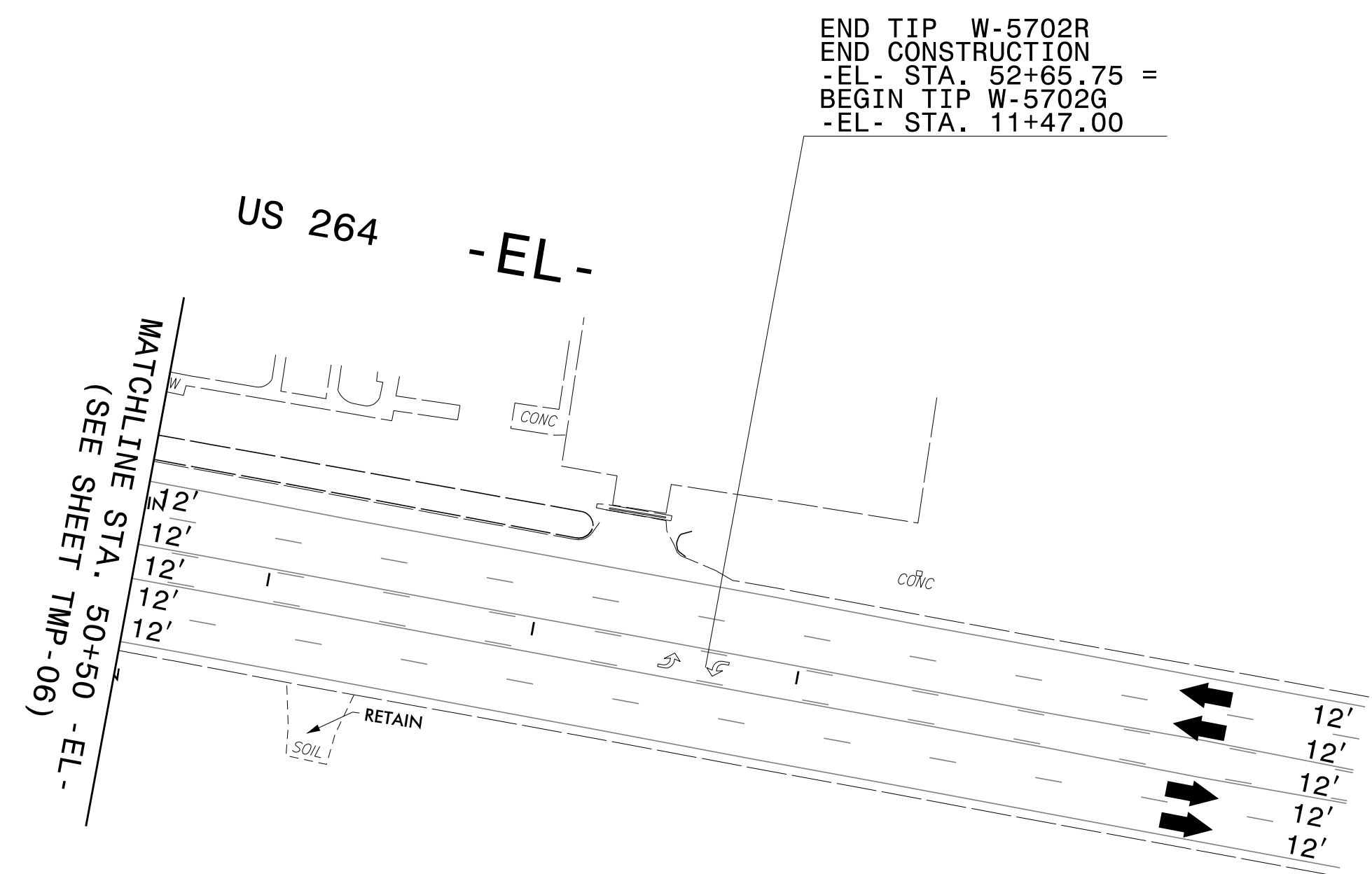
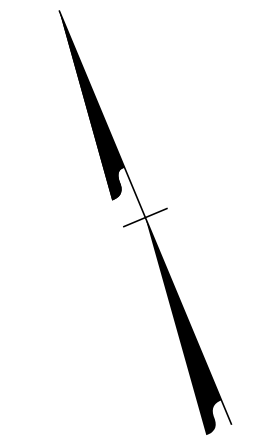

PHASE I DETAIL



12/11/2023
 P:\2019\915101\W-5702R-Superstreet-Traffic\Traffic\Traffic Design\Design\Pre-Let\Plan\WZTC\Sheets\W-5702GR-TMP-07_Phl.dgn
 User: AHayes

1223 Jones Franklin Rd.
 Raleigh, N.C. 27606
 License No. F-0377
 Bus: 919 851 8077
 Fax: 919 851 8107

TRANSPORTATION PLANNING/DESIGN - BRIDGE/STRUCTURE DESIGN
 CIVIL/SITE DESIGN - GIS/GPS - CONSTRUCTION OBSERVATION

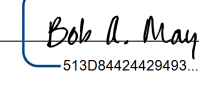
APPROVED: 
 DATE: 12/11/2023

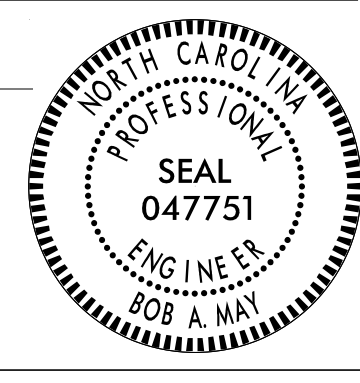

DOCUMENT NOT CONSIDERED FINAL UNLESS ALL SIGNATURES COMPLETED



PHASE I DETAIL

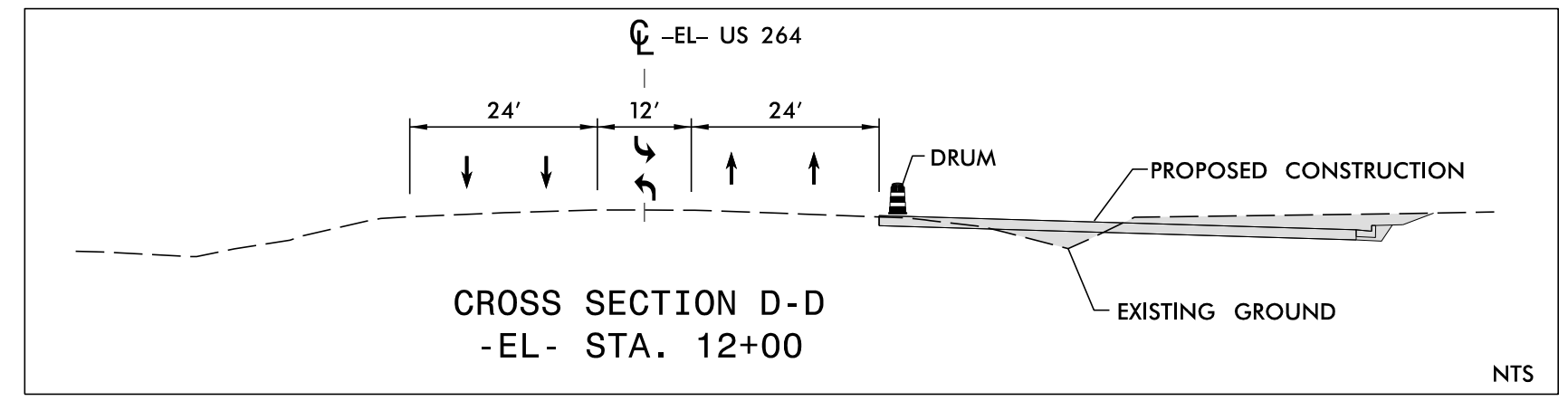
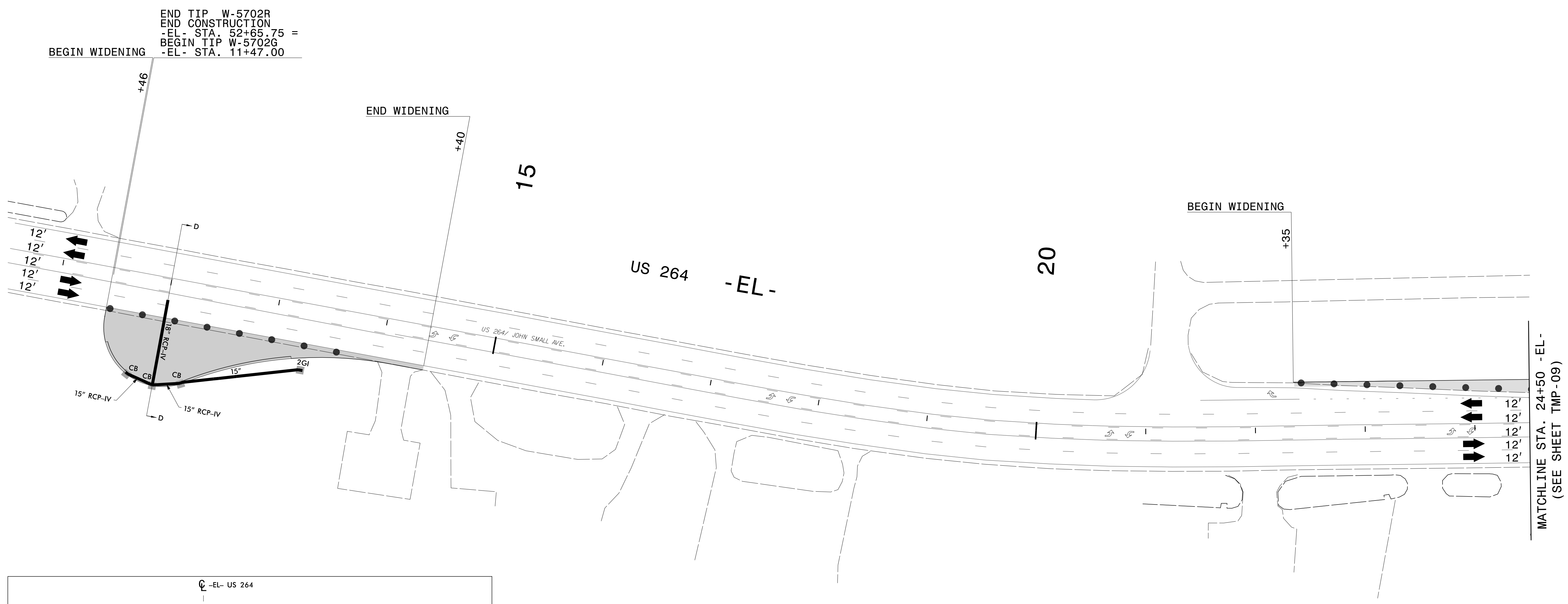
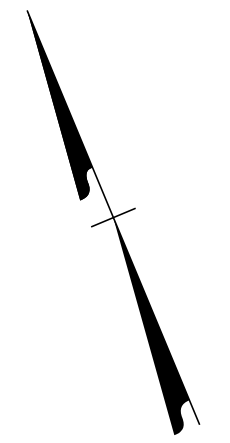

12/11/2023
 P:\2019\915101_W-5702R_Superstreet\Traffic\Design\Pre-Let\Plan\WZTC\Sheets\W-5702GR_TMP_08_Phl.cgn
 User: AHayes

MATCHLINE STA. 24+50 -EL-
 (SEE SHEET TMP-09)

1223 Jones Franklin Rd.
 Raleigh, N.C. 27606
 License No. F-0377
 Bus: 919 851 8077
 Fax: 919 851 8107

WETHERILL ENGINEERING
 TRANSPORTATION PLANNING/DESIGN - BRIDGE/STRUCTURE DESIGN
 CIVIL/SITE DESIGN - GIS/GPS - CONSTRUCTION OBSERVATION

APPROVED: *Bob A. May*
 DATE: 12/11/2023

SEAL
 047751
 ENGINEER
 BOB A. MAY

**DOCUMENT NOT CONSIDERED FINAL
 UNLESS ALL SIGNATURES COMPLETED**

DIVISION OF HIGHWAYS
 STATE OF NORTH CAROLINA
 DEPARTMENT OF TRANSPORTATION
 WORK ZONE TRAFFIC CONTROL

PHASE I DETAIL

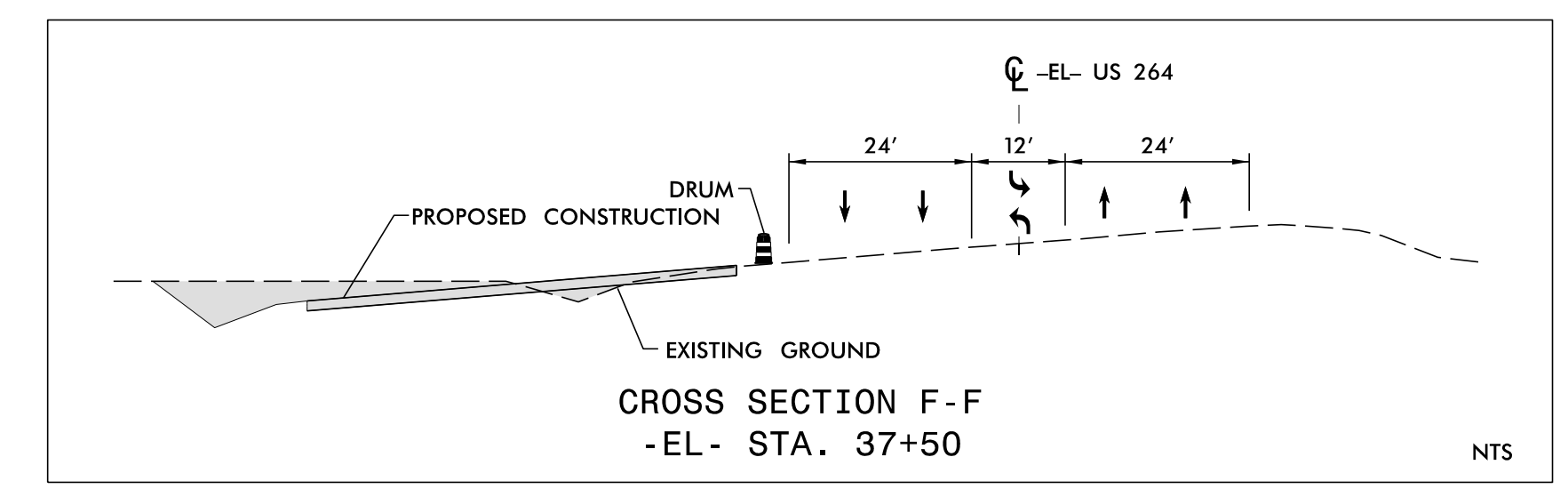
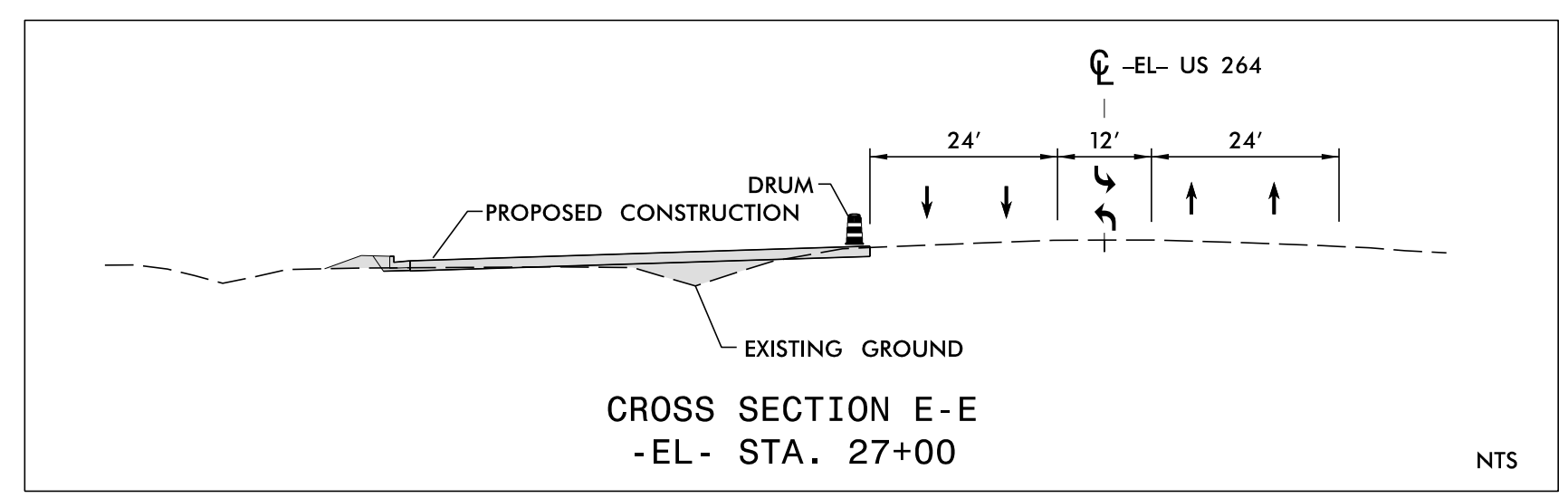
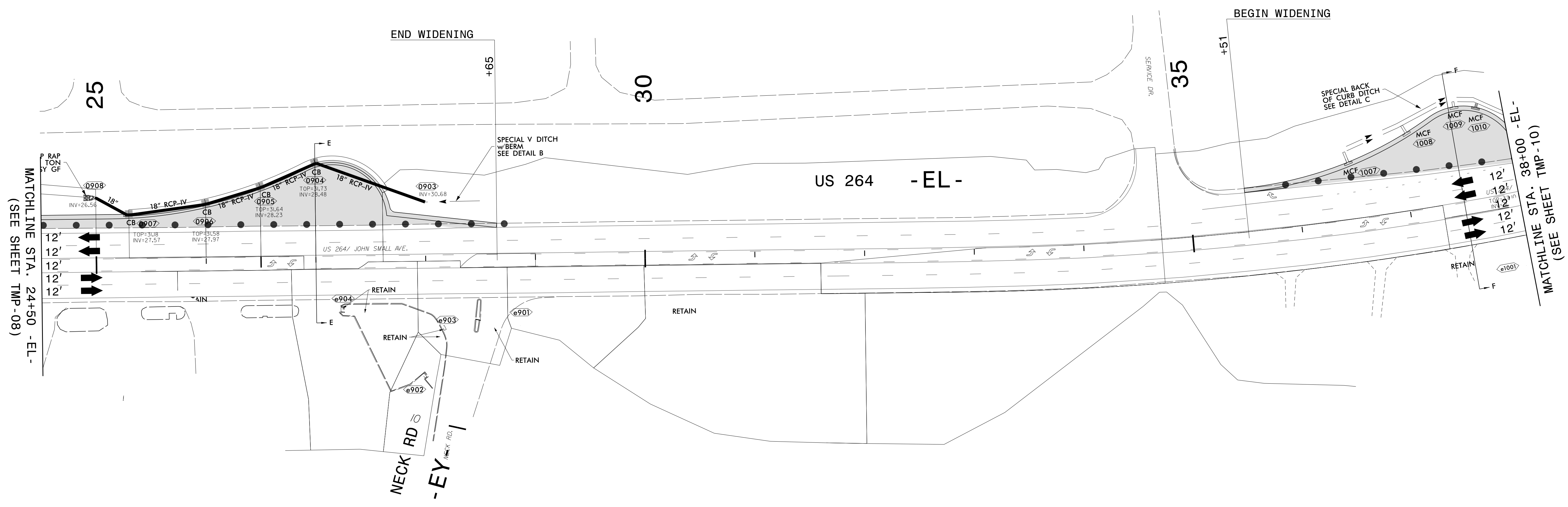
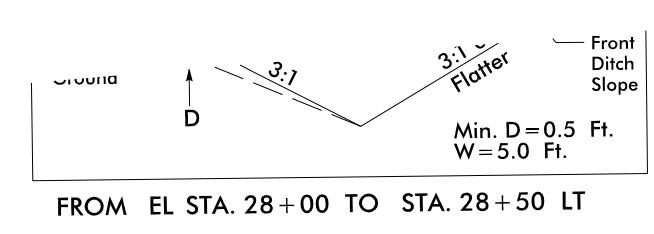
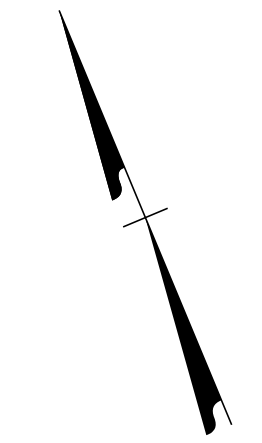

12/11/2023
 P:\2019\915101_W-5702R_Superstreet+Traffic\Traffic\Design\Pre-Let\Plan\WZTC\Sheets\W-5702GR_TMP_09_Phl.cgn
 User: AHayes

1223 Jones Franklin Rd.
 Raleigh, N.C. 27606
 License No. F-0377
 Bus: 919 851 8077
 Fax: 919 851 8107

APPROVED: *Bob A. May*
DocuSigned by:
51328442429493
 DATE: 12/11/2023

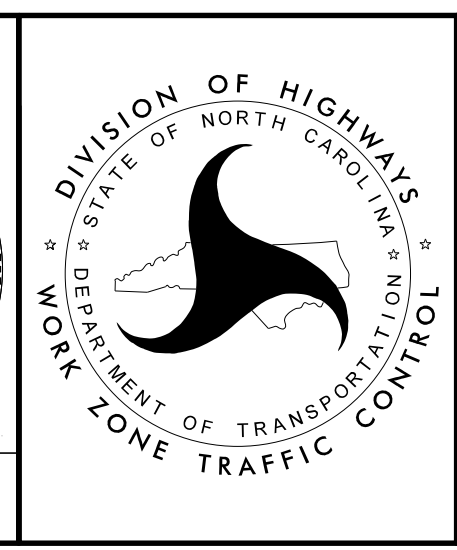

PHASE I DETAIL

DOCUMENT NOT CONSIDERED FINAL
UNLESS ALL SIGNATURES COMPLETED

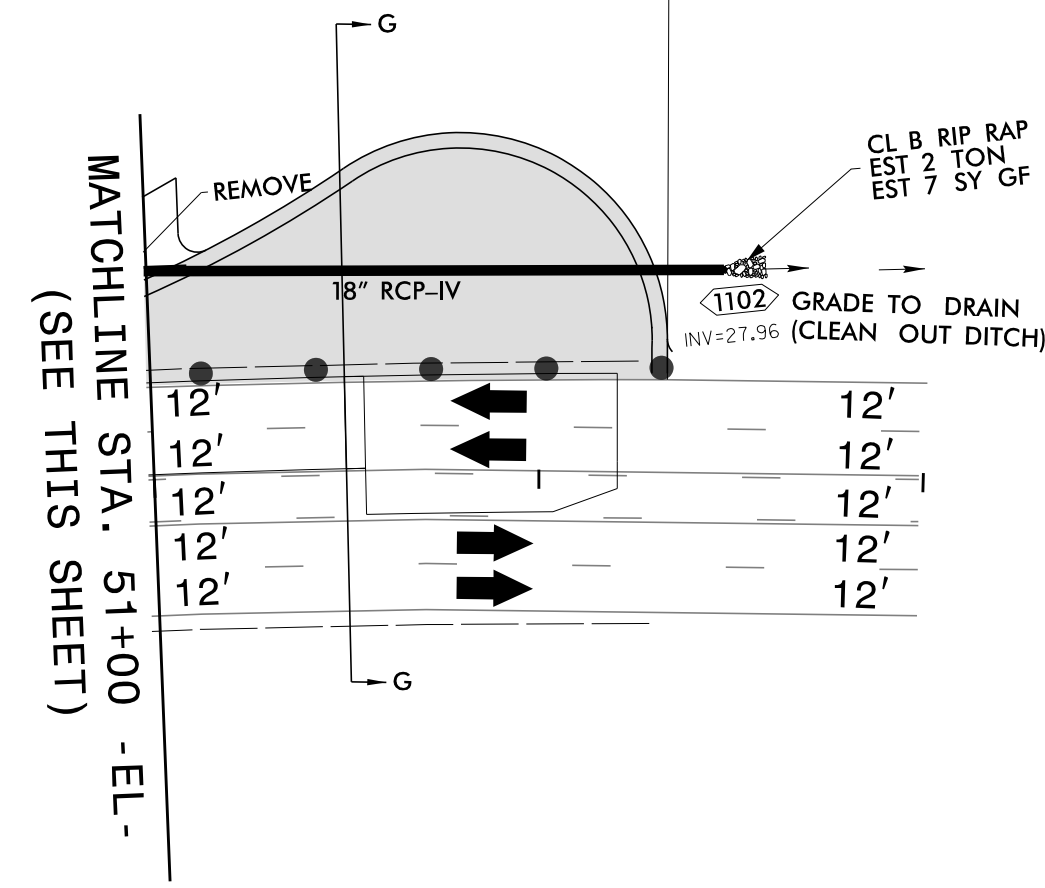
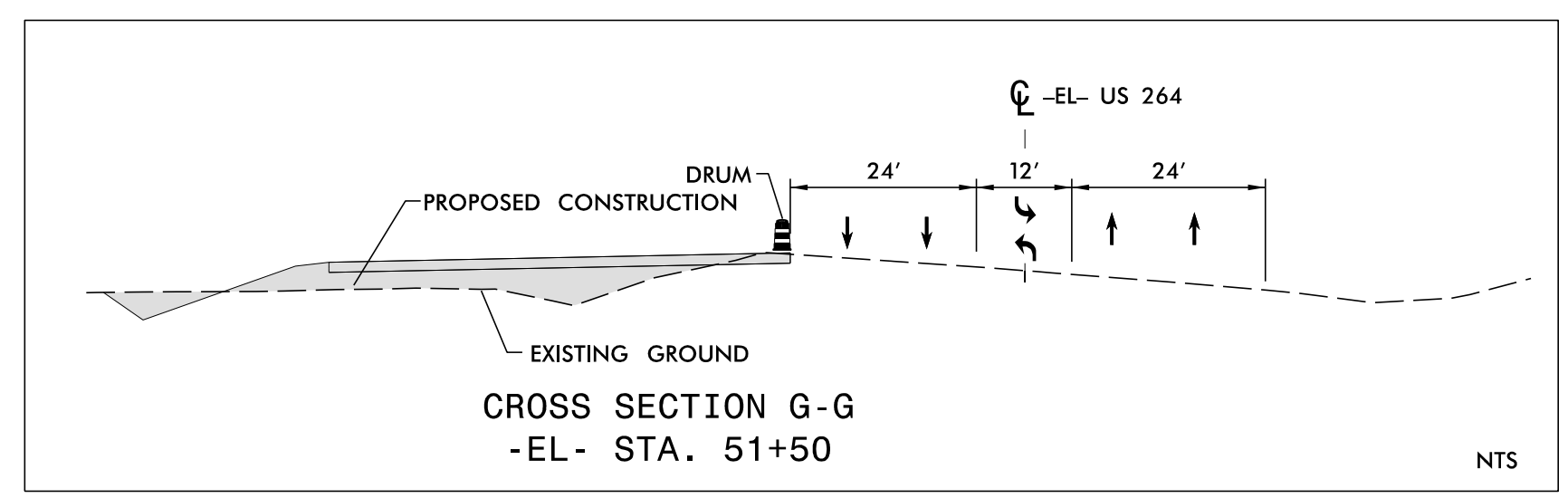
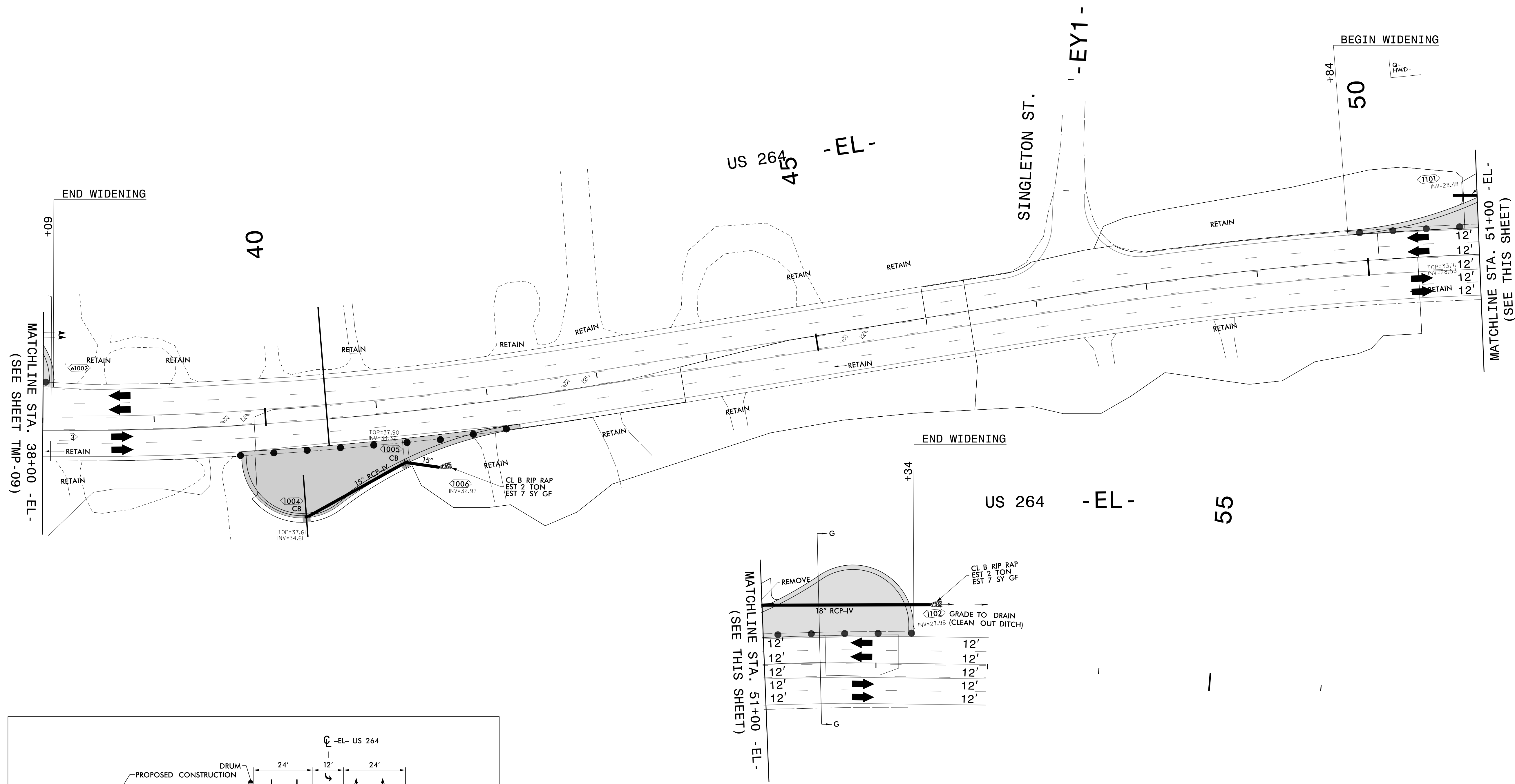

12/11/2023
 P:\2019\915101_W-5702R-Superstreet\Traffic\Design\Pre-Let\Plan\WZTC\Sheets\W-5702GR_TMP_10_Phd.dgn
 User: AHayes

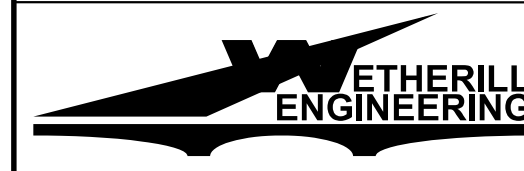
 1223 Jones Franklin Rd.
 Raleigh, N.C. 27606
 License No. F-0377
 Bus: 919 851 8077
 Fax: 919 851 8107

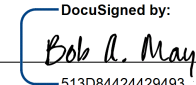
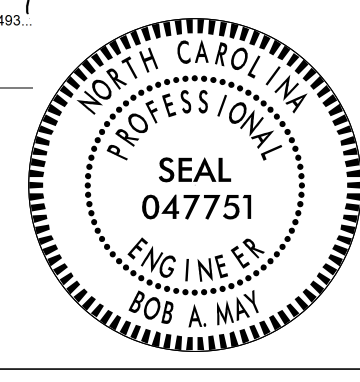
APPROVED: 
 DATE: 12/11/2023

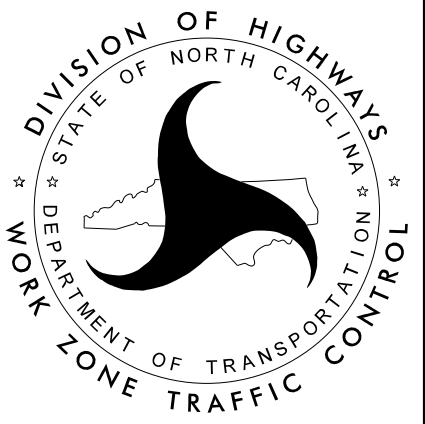
**DOCUMENT NOT CONSIDERED FINAL
 UNLESS ALL SIGNATURES COMPLETED**

 DIVISION OF HIGHWAYS
 STATE OF NORTH CAROLINA
 DEPARTMENT OF TRANSPORTATION
 WORK ZONE TRAFFIC CONTROL

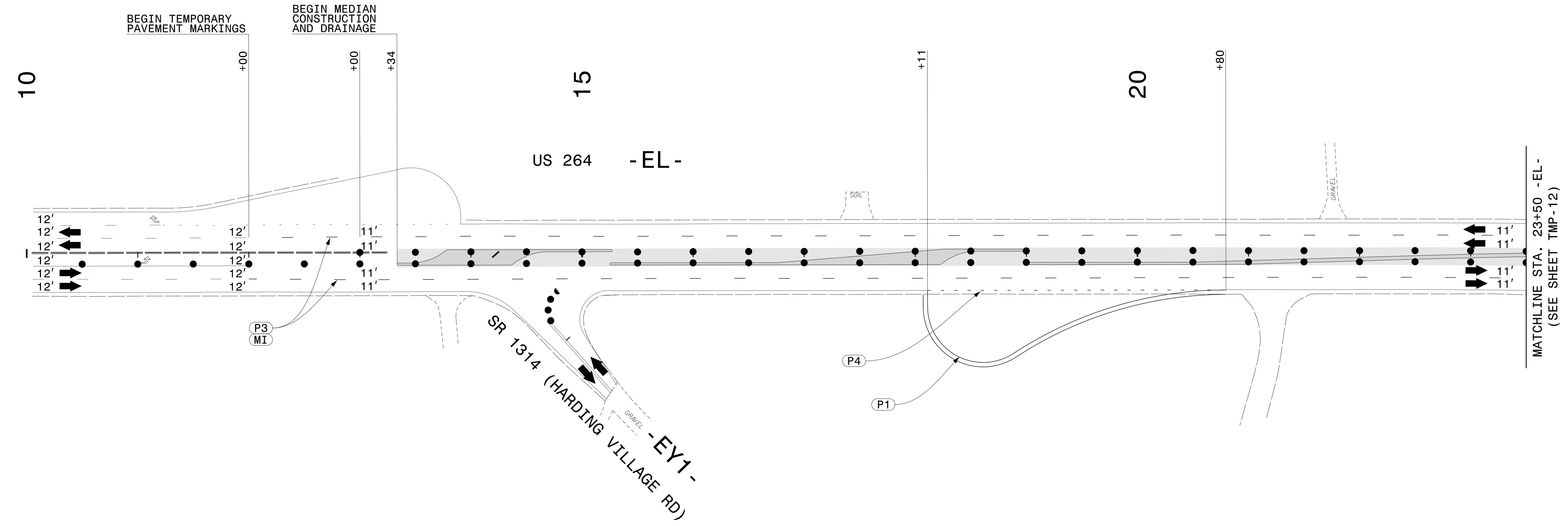
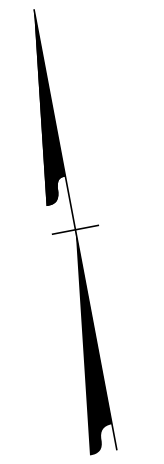
PHASE I DETAIL



12/11/2023
 P:\2019\915101_W-5702R_Superstreet+Traffic\Traffic\Design\Pre-Let\Plan\WZTC\Sheets\W-5702GR_TMP_IL.PHI.dgn
 User: AHayes

1223 Jones Franklin Rd.
 Raleigh, N.C. 27606
 License No. F-0377
 Bus: 919 851 8077
 Fax: 919 851 8107

TRANSPORTATION PLANNING/DESIGN - BRIDGE/STRUCTURE DESIGN
 CIVIL/SITE DESIGN - GIS/GPS - CONSTRUCTION OBSERVATION

APPROVED:
DocuSigned by: Bob A. May 51308442420403
 DATE: 12/11/2023

DOCUMENT NOT CONSIDERED FINAL UNLESS ALL SIGNATURES COMPLETED

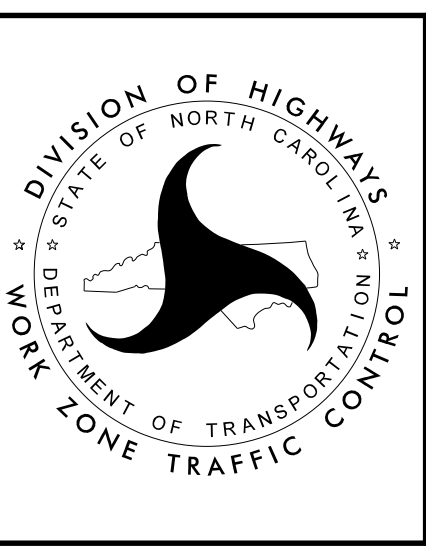

PHASE II DETAIL

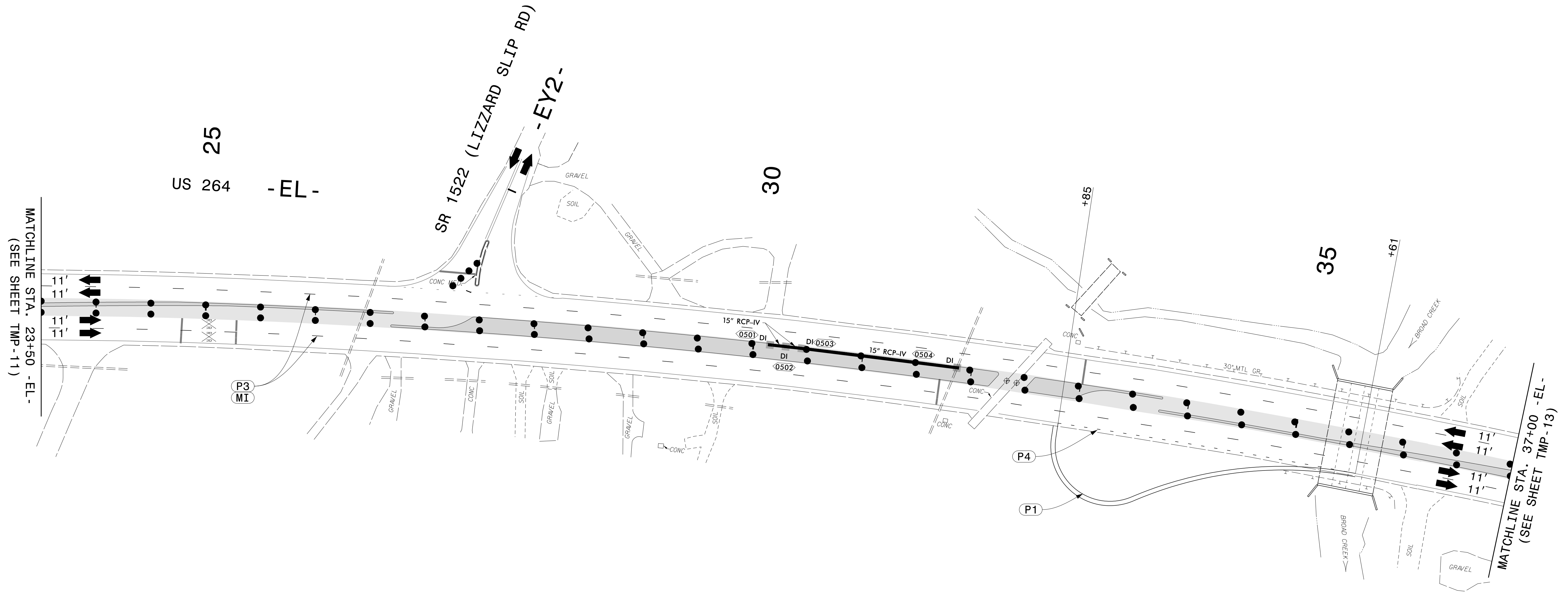
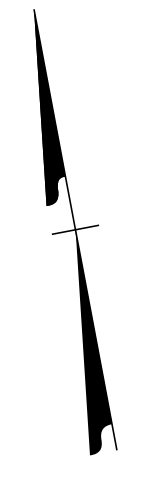

12/11/2023
 P:\2019\915101_W-5702R_Superstreet+Traffic\Traffic\Traffic Design\Design\Pre-Let\Plan\WZTC\Sheets\W-5702GR_TMP_L2_Phil.dgn
 User: AHayes

1223 Jones Franklin Rd.
 Raleigh, N.C. 27606
 License No. F-0377
 Bus: 919 851 8077
 Fax: 919 851 8107

TRANSPORTATION PLANNING/DESIGN - BRIDGE/STRUCTURE DESIGN
 CIVIL/SITE DESIGN - GIS/GPS - CONSTRUCTION OBSERVATION

APPROVED: *Bob A. May*
DocuSigned by:
513084624420493
 DATE: 12/11/2023

**DOCUMENT NOT CONSIDERED FINAL
UNLESS ALL SIGNATURES COMPLETED**



PHASE II DETAIL

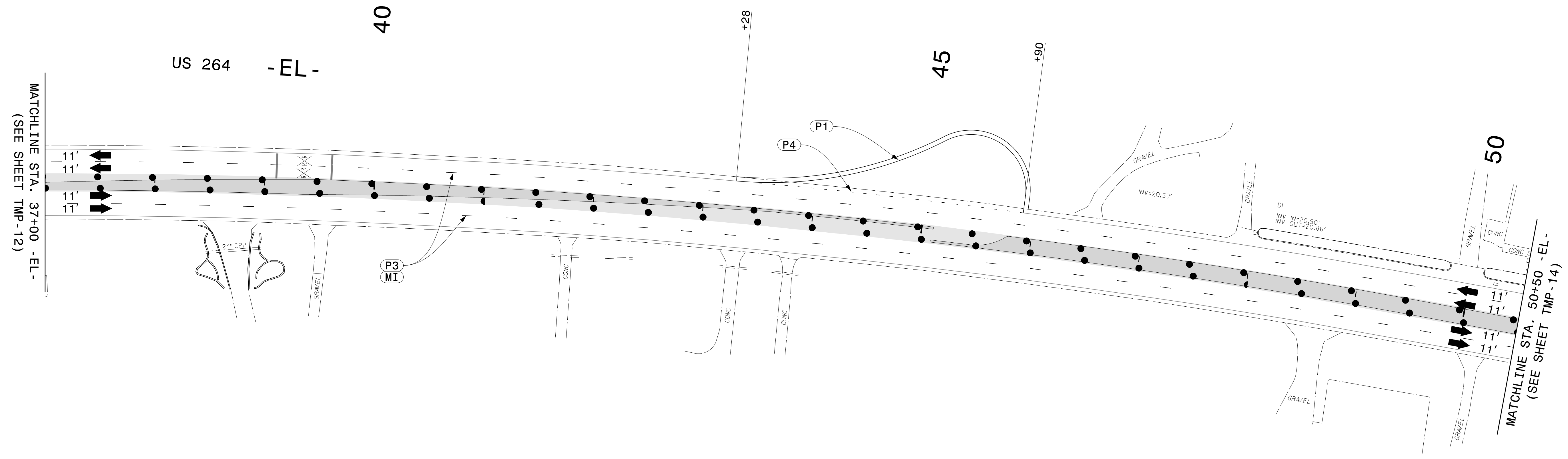
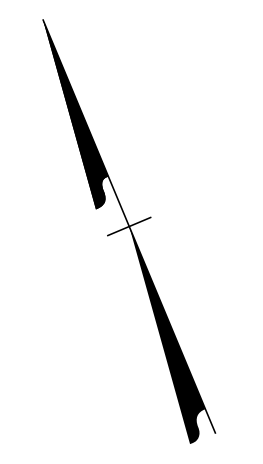

12/11/2023
 P:\2019\915101_W-5702R_Superstreet\Traffic\Design\Pre-Let\Plan\WZTC\Sheets\W-5702GR_TMP_13_Phil.dgn
 User: AHayes

1223 Jones Franklin Rd.
 Raleigh, N.C. 27606
 License No. F-0377
 Bus: 919 851 8077
 Fax: 919 851 8107

TRANSPORTATION PLANNING/DESIGN - BRIDGE/STRUCTURE DESIGN
 CIVIL/SITE DESIGN - GIS/GPS - CONSTRUCTION OBSERVATION

APPROVED: *Bob A. May*
DocuSigned by:
51308442429493
 DATE: 12/11/2023

**DOCUMENT NOT CONSIDERED FINAL
UNLESS ALL SIGNATURES COMPLETED**



PHASE II DETAIL

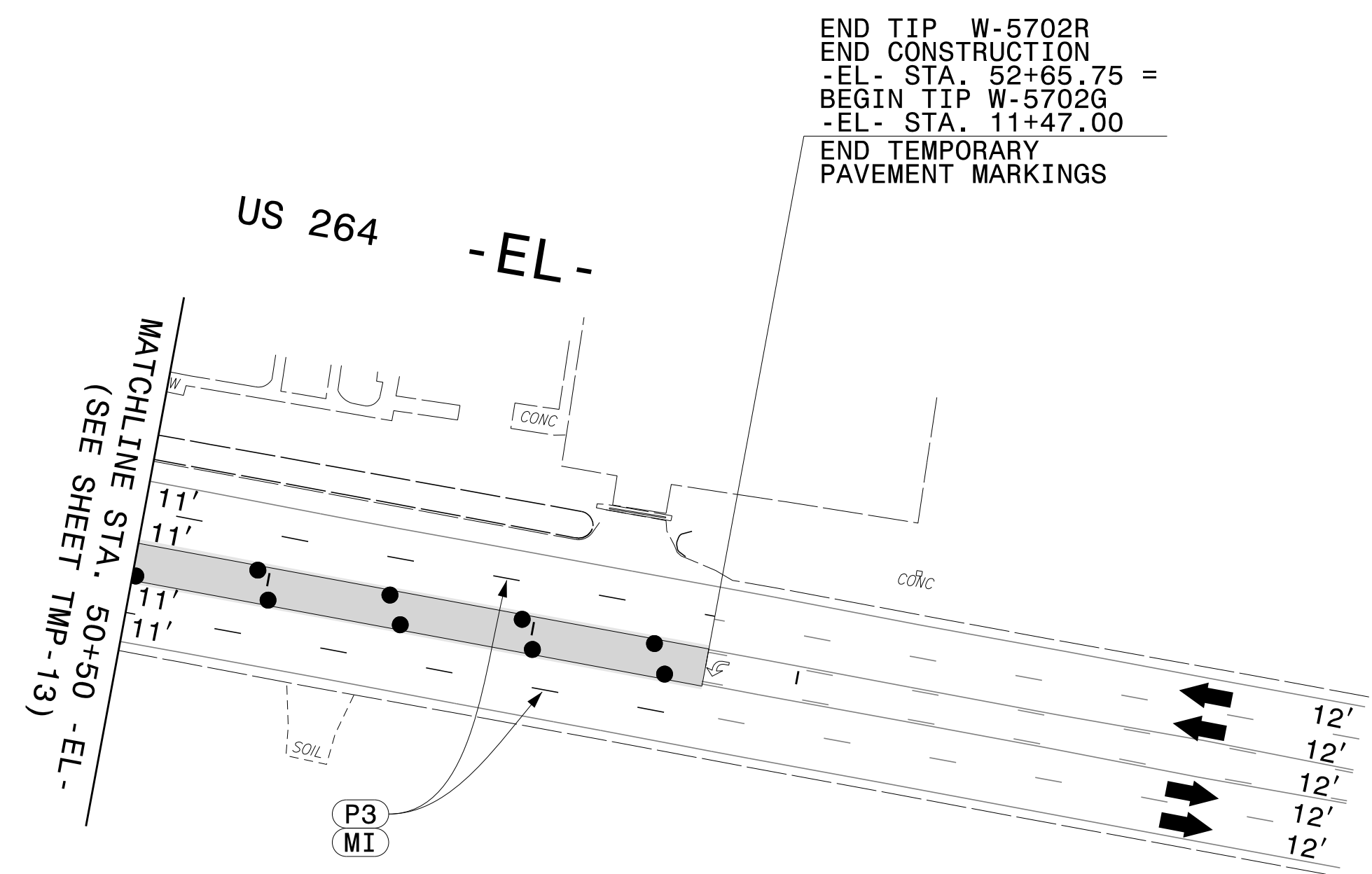
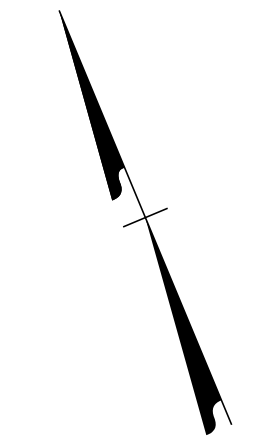

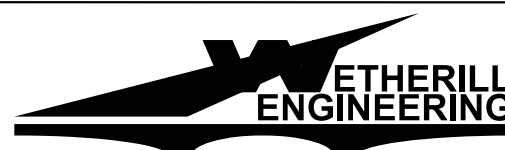

12/11/2023
 P:\2019\915101\W-5702R-Superstreet-Traffic\Traffic\Traffic Design\Design\Pre-Let\Plan\WZTC\Sheets\W-5702GR-TMP-14_Phil.dgn
 User: AHayes

PHASE II DETAIL



 1223 Jones Franklin Rd.
 Raleigh, N.C. 27606
 License No. F-0377
 Bus: 919 851 8077
 Fax: 919 851 8107

TRANSPORTATION PLANNING/DESIGN - BRIDGE/STRUCTURE DESIGN
 CIVIL/SITE DESIGN - GIS/GPS - CONSTRUCTION OBSERVATION

APPROVED: 
DocuSigned by:
Bob A. May
51308424429493
 DATE: 12/11/2023

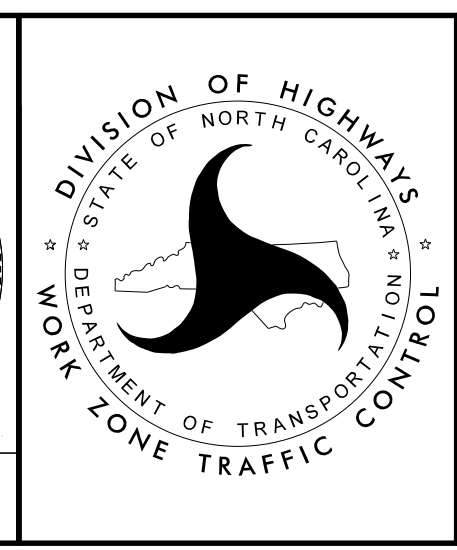

**DOCUMENT NOT CONSIDERED FINAL
UNLESS ALL SIGNATURES COMPLETED**



PHASE II DETAIL

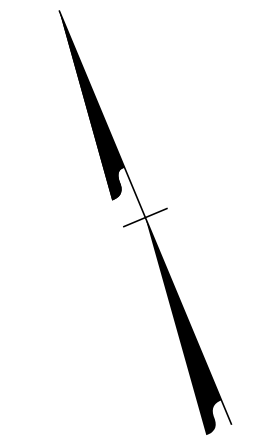

BEGIN MEDIAN
CONSTRUCTION
AND DRAINAGE

END TIP W-5702R
END CONSTRUCTION
-EL- STA. 52+65.75 =
BEGIN TIP W-5702G
-EL- STA. 11+47.00

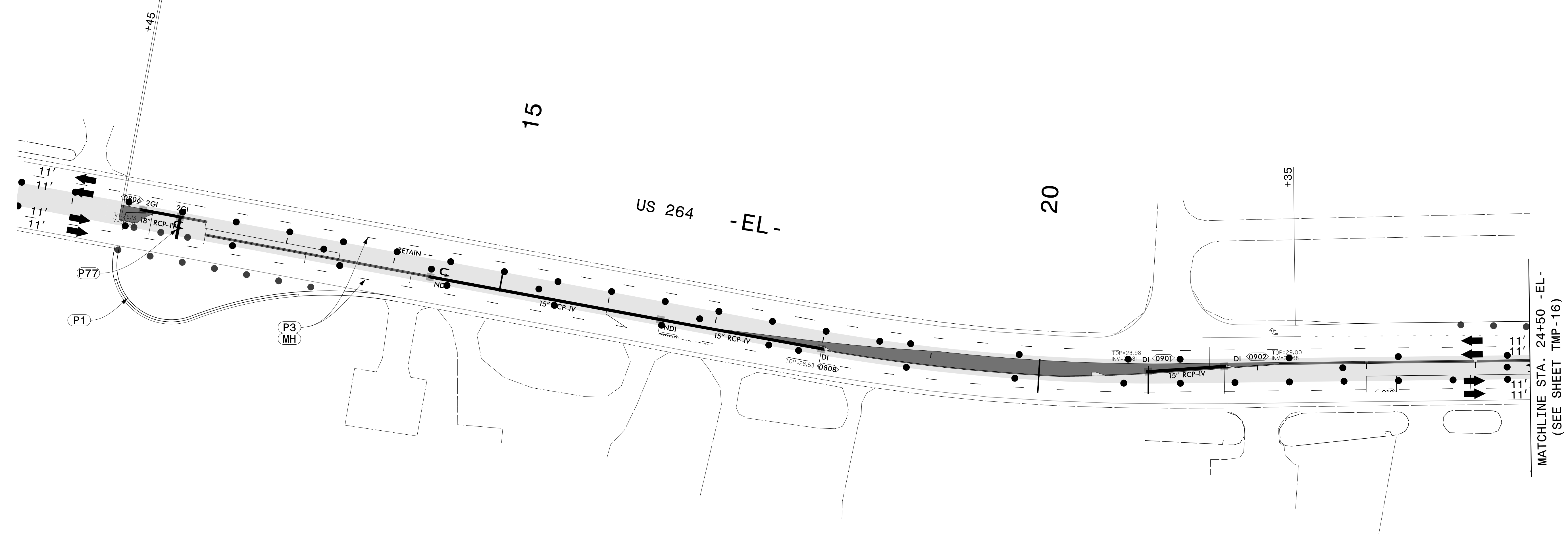

12/11/2023
 P:\2019\915101_W-5702R_Superstreet\Traffic\Traffic\Traffic Design\Design\Pre-Let\Plan\WZTC\Sheets\W-5702GR_TMP_15_Phil.dgn
 User: AHayes

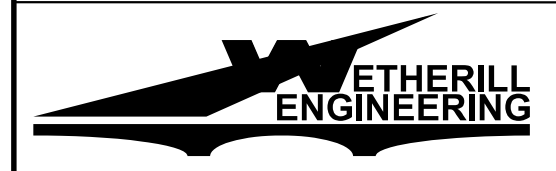
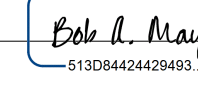
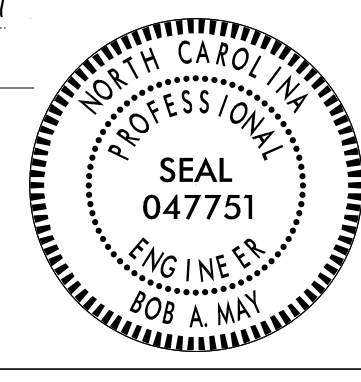
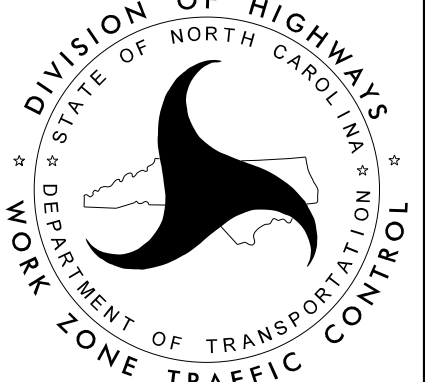
 <p>1223 Jones Franklin Rd. Raleigh, N.C. 27606 License No. F-0377 Bus: 919 851 8077 Fax: 919 851 8107</p> <p>TRANSPORTATION PLANNING/DESIGN - BRIDGE/STRUCTURE DESIGN CIVIL/SITE DESIGN - GIS/GPS - CONSTRUCTION OBSERVATION</p>	<p>APPROVED:  DATE: 12/11/2023</p>	 <p>DOCUMENT NOT CONSIDERED FINAL UNLESS ALL SIGNATURES COMPLETED</p>		<p>PHASE II DETAIL</p>
--	---	---	---	------------------------

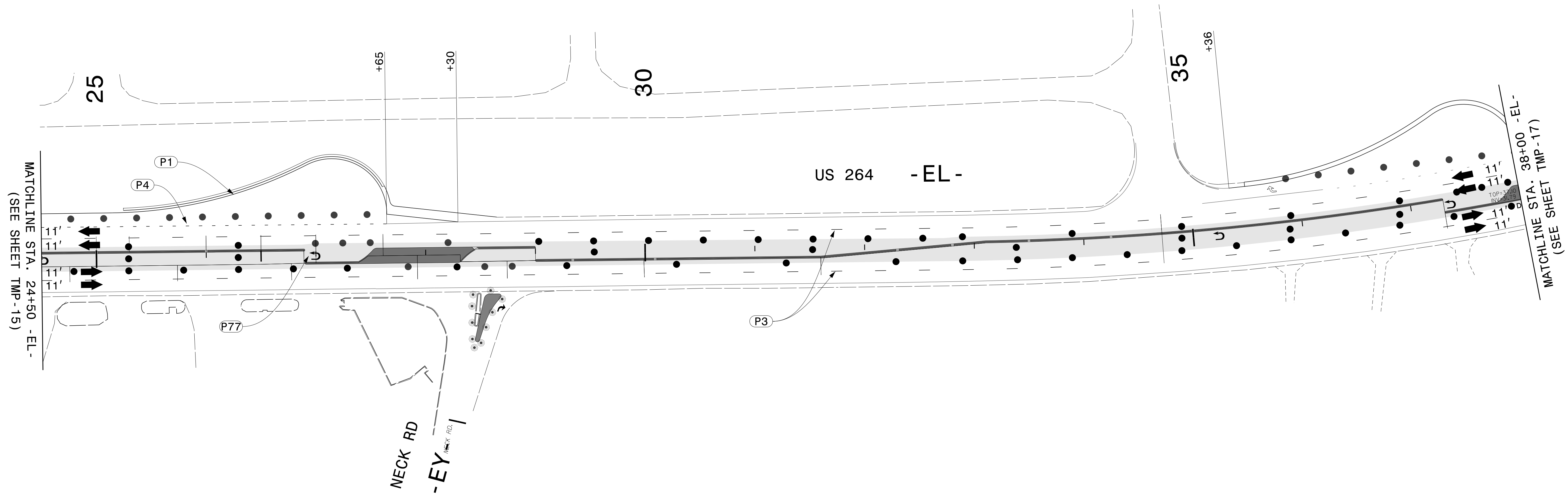
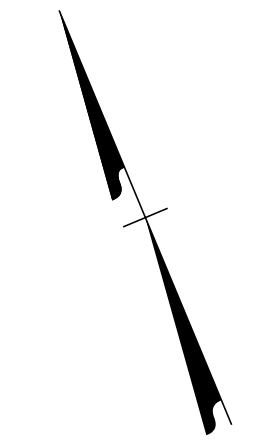

12/11/2023
 P:\2019\915101_W-5702R_Superstreet+Traffic\Traffic\Traffic Design\Design\Pre-Let\Plan\WZTC\Sheets\W-5702GR_TMP_16_Phil.dgn
 User: AHayes



1223 Jones Franklin Rd.
 Raleigh, N.C. 27606
 License No. F-0377
 Bus: 919 851 8077
 Fax: 919 851 8107

TRANSPORTATION PLANNING/DESIGN - BRIDGE/STRUCTURE DESIGN
 CIVIL/SITE DESIGN - GIS/GPS - CONSTRUCTION OBSERVATION

APPROVED: *Bob A. May*
DocuSigned by:
513084424204093
 DATE: 12/11/2023

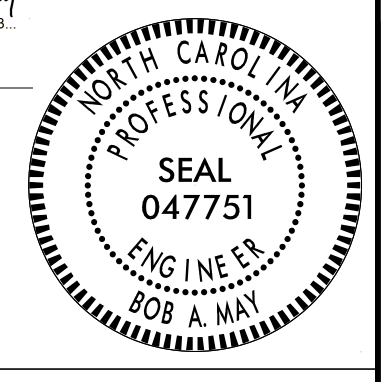

**DOCUMENT NOT CONSIDERED FINAL
UNLESS ALL SIGNATURES COMPLETED**

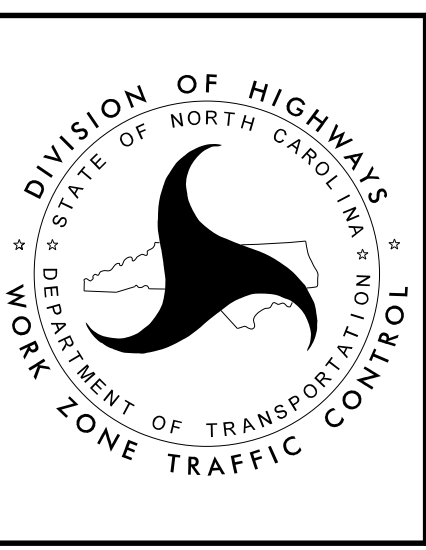

PHASE II DETAIL

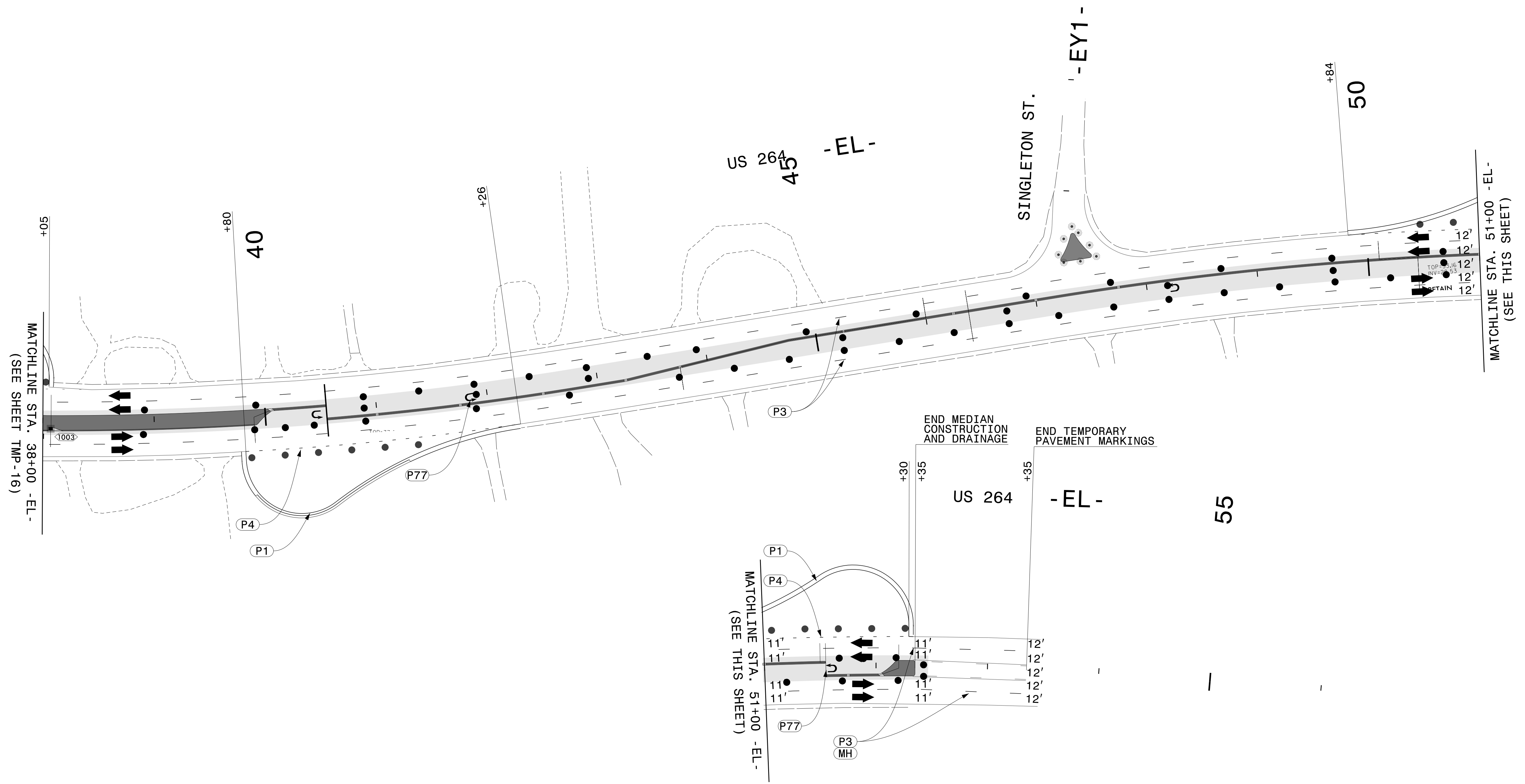

12/11/2023
 P:\2019\915101_W-5702R_Superstreet\Traffic\Design\Pre-Let\Plan\WZTC\Sheets\W-5702GR_TMP_17_Phil.dgn
 User: AHayes

ETHERILL ENGINEERING

1223 Jones Franklin Rd.
 Raleigh, N.C. 27606
 License No. F-0377
 Bus: 919 851 8077
 Fax: 919 851 8107

TRANSPORTATION PLANNING/DESIGN - BRIDGE/STRUCTURE DESIGN
 CIVIL/SITE DESIGN - GIS/GPS - CONSTRUCTION OBSERVATION

APPROVED: *Bob A. May*
 DATE: 12/11/2023

51308442429493

SEAL
 047751
 ENGINEER
 BOB A. MAY

**DOCUMENT NOT CONSIDERED FINAL
 UNLESS ALL SIGNATURES COMPLETED**

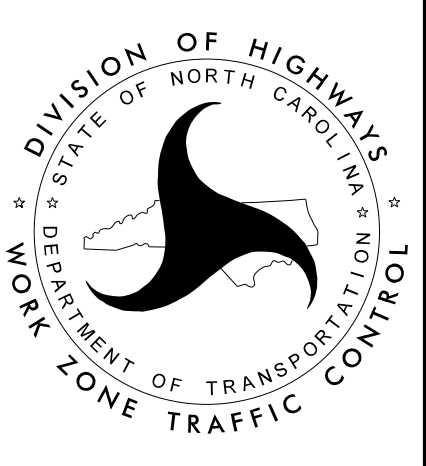

PHASE II DETAIL